



The new degree of comfort.™

High Efficiency

Low Height Air Handler With Side Discharge Condensing Unit

**RSIN - RSON Scroll
Compressor Series**

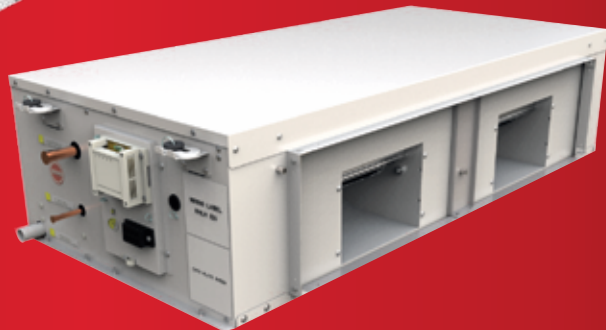



The new degree of comfort.™



NOMENCLATURE

Outdoor Unit:

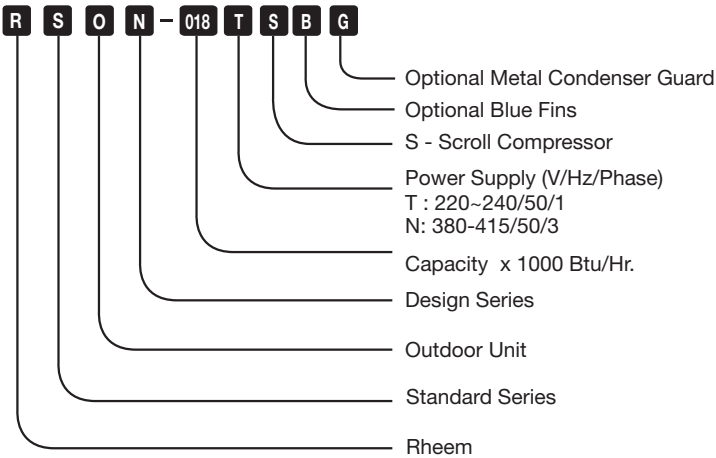

Indoor Unit:

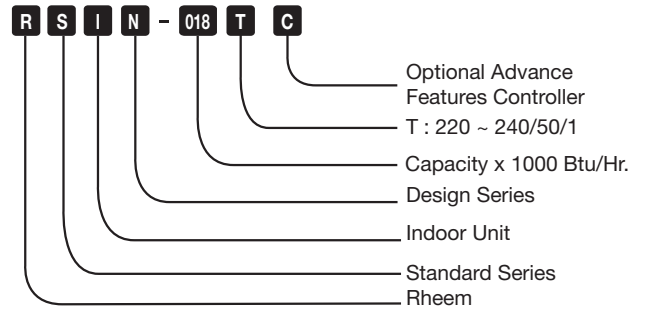

ENGINEERING FEATURES

Indoor Units

Cabinet:

Polyester based powder coated, made from hot dip galvanized steel sheet metal for high corrosion resistance of 1008 hrs salt spray test as per ASTM-B117 std.



Motor:

Multi speed, internally protected ultra high efficiency with Class-B insulation mounted on resilient neoprene rubber mountings to reduce noise level.

Ultra high efficiency and low RPM 6 Pole motors:



Motor Mounting Arrangement:

Specially designed mounting arrangement for motors to have center alignment of motor and fan blower assembly with hoRSING, which provides absolute sturdiness against vibrations.



Silent Operation:

The motor and fans are designed to achieve performance by running at lower RPM to reduce tip speeds for extremely silent operation. Motors used in the units are 6 pole. The fans are designed to operate at lower blower outlet and coil face velocity for quiet and highly efficient operation of units.

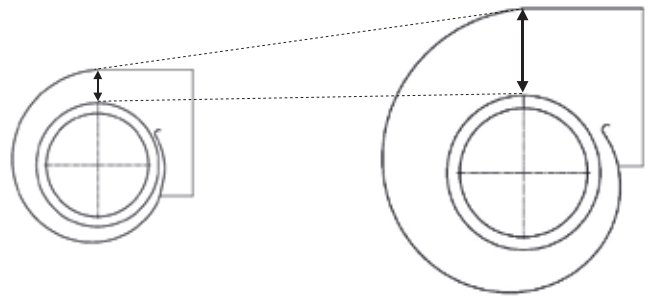

Low Height:

Height 12 to 16 inches. Allows for horizontal installation in most standard or replacement work.

Brass Distributor:

Distributor is used in all the indoor units to uniformly distribute refrigerant in the evaporator circuits for best performance in the evaporator coil.

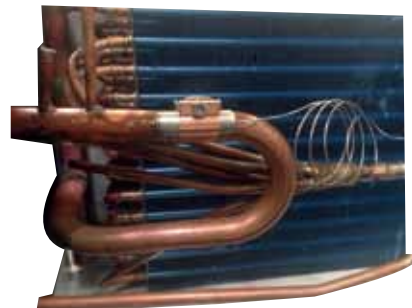

ENGINEERING FEATURES

Blower:

Direct driven, centrifugal, forward curved, double inlet double width type, made from galvanized steel sheet.

Blower HoRSiNG:

Double inlet orifice, profile to give advantage in low noise, high efficiency and uniform air flow, made from galvanized steel sheet.



Old Conventional Design



New Design

Insulation:

Irradiated grade EPE, fire retardant, odour free material for thermal, hygiene and acoustic application.



Evaporator Coil :

Coils are constructed with inner grooved copper tubes (IGT) and aluminium fins. Fins mechanically bonded to the tubes for maximum heat transfer capabilities. Coated highly corrosion resistant aluminium fins are provided as standard features in all the units.

Antifreeze Protection For Coil :

Antifreeze temperature sensor is provided on coil against freezing during abnormal operating conditions.

Refrigerant Connections :

For field piping connections, sweat solder type joints are provided outside the unit. Rubber plugs with positive pressure inside the coil are provided on the connection for ease of installation.

Drain Pan:

Insulated and powder coated galvanized steel drain pan is designed with adequate slope to have proper condensate drain. The sandwich insulation kept between upper and lower sheet metal panels provides drip free performance.

Drain Pan Cleaning:

The construction of cabinet is designed to remove the drain pan for servicing and cleaning purpose through bottom access under installed condition without disturbing the installation of the unit.

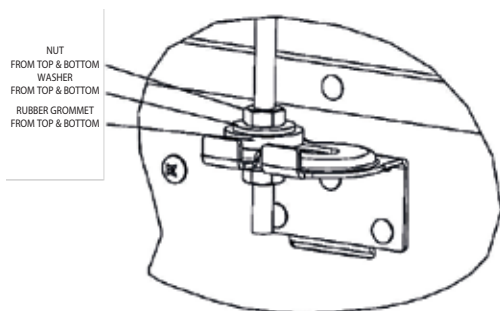

Unit Suspension:

Rolled up rigid brackets for proper and easy mounting / installation of units. Rubberized cushions are provided at hanging brackets for suspending the unit from the ceiling / concrete slab to eliminate vibration.

Filters:

5mm thick woven synthetic, permanent washable filters are standard on all units. Provision for fixing 1/2" thick field supplied filters is a standard feature on all the units.



Service Access:

Removable panels at the bottom of the unit are provided for service access to blower, blower hoRSiNG, motors and expansion device. Entire fan and motor section assembly can be separated from the cabinet by opening special bolts for servicing and maintenance purposes in all the units. This feature provides the complete access of components without opening the ducting and refrigerant connections. Filter access provision is made without removing any part of unit (Lift and Remove from backside).

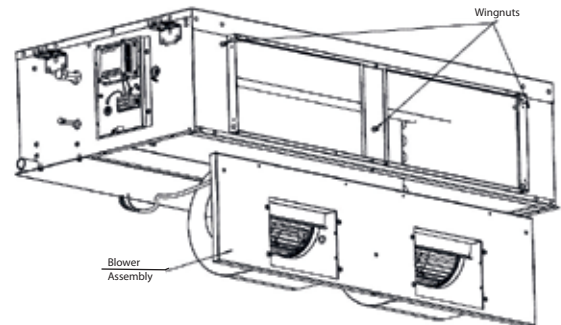

Microprocessor Based Controller:

Microprocessor based electronic controller with built-in programming for complete control of system, time delays for refrigeration systems protection and interlocking arrangement with safeties are provided as standard features on all the indoor units.

Controller Features:

- Standard with all units
- Microprocessor based unit
- High pressure and low pressure protection
- Antifreeze protection
- Built-in time delay for compressor

Advance Controller Features (Optional):

- Weekly Scheduling
- Remote ON/OFF
- BMS Compatibility
- Wireless remote controller
- Drain Pump supply



ENGINEERING FEATURES

Connecting Cable Flexibility:

Quick connector is provided for interconnecting communication cable (10 meter long) from main controller to Controller User Interface. This provides flexibility for quick connections, avoiding miss connections in terminals and ensures safety to service personnel.



Provision For Direct Duct Connection:

Flanges are provided on the front of units, suitable to connect flexible duct.

Riveted Panels:

Non serviceable panels in the cabinet are joined with the help of rigid steel rivets. The riveted panel provides very good stability, fit and finish.

Outdoor Units

Compressor:

Compressors used in the units are hermetically sealed scroll type and incorporate internal high temperature motor overload protection, and durable insulation on the motor winding. The compressors used are tropical compressors optimized for performance and reliability for high temperature environmental conditions. Internally it is spring mounted and externally mounted on rubber grommets to reduce vibration and noise.

Condenser Fan Motor:

Internally protected, totally enclosed Class B insulation and permanently lubricated type motors are tested for high ambient operation.

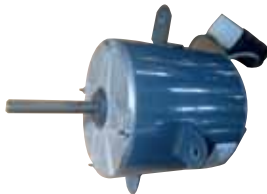

Fan:

Metallic Condenser fan blades ensure safety and high durability. Suitable for operation in high ambient temperature and heavy wind pressure.



Fan Guard:

Metallic wire guard confirms to IEC safety standard and high durability.

Cabinet:

Polyester Powder coated, made from hot dip galvanized steel sheet metal for high corrosion resistance of 1008 hrs salt spray as per ASTM-B117 std. Pressed parts like Base, Foot, Top, Front, Fan Motor Bracket and Side grille add sturdiness to the cabinet.

Refrigerant Connections:

All connections are sweat and soldered type on exterior of the unit, located close to the ground for neat appearing installation.

Service Valves:

Standard on all models. These valves are provided outside the unit with service port for connecting gauges the ease of installation, additional refrigerant charging and monitoring of system.



Serviceability:

The compressor and the electrical box is located in separate compartment of the cabinet providing for easy access through service panel.



Filter Drier:

Filter drier is supplied loose as standard accessory with the units for installation in liquid line in field. The filter drier prevents the unwanted moisture in the system and helps in enhancing the life of the system.



Precharged:

Every unit is factory charged and run tested before shipment.

Pressure Cut-Outs:

High Pressure and Low Pressure safety controls are a standard feature on all the models.



Condenser Coil:

Coils are constructed with inner grooved copper tube (IGT) and aluminum fins mechanically bonded to the tubes for maximum heat transfer capabilities (Optional coated highly corrosion resistant aluminium fins.)



OPERATING RANGE & PHYSICAL AND ELECTRICAL DATA

TABLE FOR TECHNICAL DATA

AIR HANDLING UNIT MODEL		RSIN-021T	RSIN-025T	RSIN-029T	RSIN-036T	RSIN-036T	RSIN-036T	RSIN-042T	RSIN-048T	RSIN-054TN
CONDENSING UNIT MODEL		RSIN-021TS	RSIN-025TS	RSIN-030TS	RSIN-036TS	RSIN-036TS	RSIN-036TS	RSIN-042NS	RSIN-048NS	RSIN-054NS
AMBIENT TEMP 95 °F	EVAP ENTERING AIR TEMP.	22.1	27.0	29.2	37.4	37.4	37.4	40.4	46.3	60.0
AMBIENT TEMP 115 °F	EVAP ENTERING AIR TEMP.	17.6	20.9	24.7	30.1	30.1	30.1	32.5	35.5	45.8
	84.2 DB / 66.2 WB *F	20.4	24.0	25.5	33.0	33.0	33.0	35.4	40.7	52.4
	LOW	20.1	23.3	25.1	31.5	31.5	31.5	34.4	40.2	50.5
	MED	745	795	1170	1200	1200	1200	1260	1250	1640
	HIGH	770	840	1225	1250	1250	1250	1390	1400	1720
	LOW	790	890	1275	1290	1290	1290	1560	1560	1825
	MED	40.8	46.3	45.8	45.4	45.4	45.4	48.1	49.1	51.8
	HIGH	41.3	46.5	46.3	45.9	45.9	45.9	49.1	50.7	52.6
	EXTERNAL STATIC PRESSURE (ESP)	41.7	47.5	47.1	46.7	46.7	46.7	50.7	52.5	53.4
	NUMBER OF COMPRESSORS	1	1	1	1	1	1	1	1	1
	NUMBER OF REFRIGERANT CIRCUIT FOR AHU	1	1	1	1	1	1	1	1	1
	EXPANSION DEVICE/REFRIGERANT - R410A	1	1	1	1	1	1	1	1	1
Orifice										
	AIR HANDLING UNIT	220-240/50/1	220-240/50/1	220-240/50/1	220-240/50/1	220-240/50/1	220-240/50/1	220-240/50/1	220-240/50/1	220-240/50/1
	CONDENSING UNIT	220-240/50/1	220-240/50/1	220-240/50/1	220-240/50/1	220-240/50/1	220-240/50/1	380-415/50/3	380-415/50/3	380-415/50/3
	AIR HANDLING UNIT	0.102	0.146	0.158	0.177	0.177	0.175	0.257	0.297	0.383
	CONDENSING UNIT	1.771	2.143	2.290	2.994	2.994	2.976	3.069	3.621	4.699
	AIR HANDLING UNIT	15	15	15	15	15	15	15	15	15
	CONDENSING UNIT	25	25	32	32	32	25	25	25	25
	AIR HANDLING UNIT	0.4	0.6	0.8	0.9	0.9	0.9	1.2	1.6	1.67
	CONDENSING UNIT	7.7	9.5	9.9	12.6	12.6	6.3	6.3	6.4	9.10
	AIR HANDLING UNIT	3.6	3.6	4.5	4.5	4.5	4.5	5.1	5.1	6.2
	CONDENSING UNIT	6.0	6.7	9.2	9.2	9.2	9.2	9.2	9.2	11.9
	AIR HANDLING UNIT	2	2	2	2	2	2	2	2	2
	CONDENSING UNIT	1	1	1	1	1	1	1	1	1
	AIR HANDLING UNIT	44	44	55	58	58	58	64	64	74
	CONDENSING UNIT	53	57	78	86	86	86	90	92	110
	AIR HANDLING UNIT	33.5	33.5	33.5	33.5	33.5	33.5	33.5	33.5	33.5
	CONDENSING UNIT	24.5	24.5	24.5	24.5	24.5	24.5	24.5	24.5	24.5
	AIR HANDLING UNIT	50	50	50	50	50	50	50	50	50
	CONDENSING UNIT	50	50	50	50	50	50	50	50	50

Ensure the operating temperature is in the allowance range.

Cooling

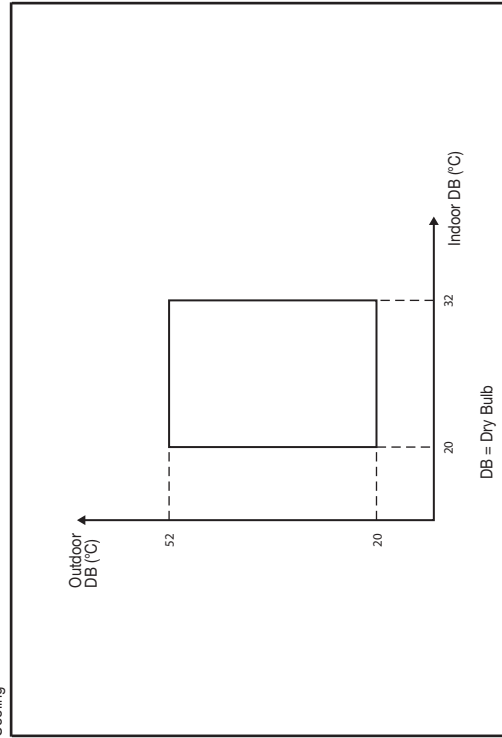

Note:

When air-conditioner is operated beyond the above specified limit for long time, the self-diagnostics function of controller may detect alarm and stop the unit to protect from permanent failure.

GROSS PERFORMANCE DATA

MODEL		RSIN-021T/RSON-021TS									
INDOOR TEMP.		80.6 °F (27.0°C) DB / 71.0 °F (21.7°C) WB			80.6 °F (27.0°C) DB / 66.2°F (19.0°C) WB			80.6 °F (27°C) DB / 63.0 °F (17.2°C) WB			
		High	Med	Low	High	Med	Low	High	Med	Low	
DEPRESSION RATIO		0.19	0.21	0.23	0.19	0.21	0.23	0.19	0.21	0.23	
AIR VOL. (CFM)		790	770	745	790	770	745	790	770	745	
O U T D O O R T E M P E R A T U R E	75°F (23.9°C)	Total Cap. (MBH)	25.6	25.5	25.4	23.9	23.8	23.7	22.6	22.5	22.4
		Sensible Cap. (MBH)	15.3	15.1	15.0	18.7	18.5	18.2	21.1	20.8	20.5
		Power (KW)	1.62	1.61	1.61	1.60	1.60	1.59	1.59	1.58	1.58
	80°F (26.7°C)	Total Cap. (MBH)	25.2	25.1	25.0	23.5	23.4	23.3	22.3	22.2	22.1
		Sensible Cap. (MBH)	15.1	14.9	14.8	18.5	18.3	18.1	21.0	20.7	20.3
		Power (KW)	1.69	1.68	1.68	1.67	1.67	1.66	1.67	1.66	1.65
	85°F (29.4°C)	Total Cap. (MBH)	24.7	24.6	24.5	23.1	23.0	22.9	21.9	21.8	21.8
		Sensible Cap. (MBH)	14.9	14.7	14.6	18.3	18.1	17.9	20.7	20.5	20.2
		Power (KW)	1.76	1.75	1.74	1.74	1.74	1.73	1.73	1.73	1.72
	90°F (32.3°C)	Total Cap. (MBH)	24.2	24.1	24.0	22.7	22.6	22.5	21.5	21.4	21.3
		Sensible Cap. (MBH)	14.6	14.5	14.4	18.1	17.9	17.7	20.5	20.2	19.9
		Power (KW)	1.82	1.82	1.81	1.81	1.80	1.80	1.80	1.80	1.79
	95°F (35.0°C)	Total Cap. (MBH)	23.6	23.6	23.5	22.2	22.1	22.0	21.0	20.9	20.8
		Sensible Cap. (MBH)	14.4	14.3	14.1	17.9	17.6	17.4	20.3	20.0	19.7
		Power (KW)	1.89	1.88	1.88	1.87	1.87	1.86	1.87	1.86	1.86
	100°F (37.8°C)	Total Cap. (MBH)	23.0	23.0	22.9	21.6	21.6	21.5	20.5	20.4	20.3
		Sensible Cap. (MBH)	14.1	14.0	13.8	17.6	17.4	17.2	20.0	19.7	19.5
		Power (KW)	1.95	1.95	1.94	1.94	1.94	1.93	1.93	1.93	1.92
	105°F (40.6°C)	Total Cap. (MBH)	22.4	22.3	22.2	21.1	21.0	20.9	20.0	19.8	19.8
		Sensible Cap. (MBH)	13.8	13.7	13.6	17.3	17.1	16.9	19.7	19.5	19.2
		Power (KW)	2.03	2.02	2.02	2.02	2.01	2.00	2.01	2.00	1.99
	110°F (43.3°C)	Total Cap. (MBH)	21.7	21.6	21.6	20.5	20.4	20.3	19.4	19.3	19.2
		Sensible Cap. (MBH)	13.5	13.4	13.2	17.0	16.8	16.6	19.3	19.1	18.9
		Power (KW)	2.10	2.10	2.09	2.09	2.09	2.08	2.08	2.08	2.07
	115°F (46.1°C)	Total Cap. (MBH)	21.0	20.9	20.8	19.8	19.8	19.6	18.9	18.7	18.6
		Sensible Cap. (MBH)	13.1	13.0	12.9	16.7	16.5	16.3	18.9	18.7	18.5
		Power (KW)	2.19	2.18	2.18	2.18	2.17	2.17	2.17	2.16	2.15
120°F (48.9°C)	Total Cap. (MBH)	20.1	20.1	20.0	19.1	19.0	19.0	18.3	18.2	18.0	
	Sensible Cap. (MBH)	12.7	12.6	12.5	16.4	16.2	16.0	18.3	18.2	18.0	
	Power (KW)	2.28	2.28	2.27	2.27	2.27	2.26	2.26	2.25	2.25	
125°F (51.7°C)	Total Cap. (MBH)	19.3	19.3	19.2	18.4	18.3	18.3	17.7	17.6	17.4	
	Sensible Cap. (MBH)	12.3	12.2	12.1	16.0	15.8	15.6	17.7	17.6	17.4	
	Power (KW)	2.39	2.38	2.38	2.37	2.37	2.36	2.37	2.36	2.35	

Power: Total Unit Input Power (KW)
 DR: Depression Ratio
 dbE: Entering Air Temperature in °F

When the entering air dry bulb temperature is other than 80.6°F,
 adjust the sensible capacity from the table by adding $1.1 \times \text{CFM} \times (1-\text{DR}) \times (\text{dbE}-80.6)$



GROSS PERFORMANCE DATA

MODEL			RSIN-025T/RSON-025TS								
			80.6 °F (27.0°C) DB / 71.0 °F (21.7°C) WB			80.6 °F (27.0°C) DB / 66.2°F (19.0°C) WB			80.6 °F (27°C) DB / 63.0 °F (17.2°C) WB		
INDOOR TEMP.			High	Med	Low	High	Med	Low	High	Med	Low
DEPRESSION RATIO			0.15	0.17	0.19	0.15	0.17	0.19	0.15	0.17	0.19
AIR VOL. (CFM)			890	840	795	890	840	795	890	840	795
O U T D O O R T E M P E R A T U R E	75°F (23.9°C)	Total Cap. (MBH)	31.7	31.5	31.2	29.4	29.2	28.9	27.8	27.6	27.4
		Sensible Cap. (MBH)	18.6	18.3	18.0	22.4	22.0	21.5	25.1	24.5	23.8
		Power (KW)	1.95	1.94	1.93	1.93	1.92	1.91	1.92	1.91	1.91
	80°F (26.7°C)	Total Cap. (MBH)	31.2	30.9	30.7	29.0	28.7	28.5	27.4	27.2	27.0
		Sensible Cap. (MBH)	18.4	18.1	17.8	22.2	21.8	21.3	24.9	24.3	23.7
		Power (KW)	2.04	2.03	2.02	2.03	2.01	2.00	2.02	2.02	2.01
	85°F (29.4°C)	Total Cap. (MBH)	30.6	30.4	30.1	28.5	28.2	27.9	26.9	26.7	26.5
		Sensible Cap. (MBH)	18.2	17.9	17.5	22.0	21.5	21.0	24.7	24.1	23.4
		Power (KW)	2.12	2.11	2.10	2.11	2.10	2.09	2.10	2.09	2.08
	90°F (32.3°C)	Total Cap. (MBH)	29.9	29.7	29.5	27.8	27.6	27.4	26.3	26.1	25.9
		Sensible Cap. (MBH)	17.9	17.6	17.2	21.7	21.2	20.7	24.4	23.8	23.2
		Power (KW)	2.20	2.19	2.18	2.19	2.18	2.17	2.18	2.17	2.16
	95°F (35.0°C)	Total Cap. (MBH)	29.2	29.0	28.8	27.2	27.0	26.7	25.7	25.5	25.3
		Sensible Cap. (MBH)	17.6	17.3	17.0	21.4	20.9	20.5	24.1	23.5	22.9
		Power (KW)	2.29	2.27	2.26	2.29	2.26	2.25	2.26	2.25	2.24
	100°F (37.8°C)	Total Cap. (MBH)	28.5	28.3	28.1	26.5	26.3	26.1	25.0	24.8	24.6
		Sensible Cap. (MBH)	17.3	17.0	16.7	21.1	20.6	20.2	23.8	23.2	22.6
		Power (KW)	2.37	2.36	2.35	2.36	2.35	2.33	2.35	2.34	2.33
	105°F (40.6°C)	Total Cap. (MBH)	27.7	27.5	27.3	25.8	25.6	25.4	24.3	24.1	24.0
		Sensible Cap. (MBH)	16.9	16.6	16.3	20.7	20.3	19.8	23.4	22.9	22.3
		Power (KW)	2.47	2.46	2.45	2.45	2.44	2.43	2.44	2.43	2.42
	110°F (43.3°C)	Total Cap. (MBH)	26.9	26.8	26.6	25.1	24.9	24.7	23.6	23.4	23.3
		Sensible Cap. (MBH)	16.6	16.3	16.0	20.4	20.0	19.5	23.2	22.5	21.9
		Power (KW)	2.59	2.57	2.56	2.56	2.55	2.54	2.55	2.54	2.52
115°F (46.1°C)	Total Cap. (MBH)	26.2	26.0	25.8	24.4	24.2	24.0	22.9	22.7	22.6	
	Sensible Cap. (MBH)	16.3	16.0	15.7	20.1	19.7	19.2	22.7	22.3	21.7	
	Power (KW)	2.72	2.70	2.69	2.69	2.68	2.66	2.67	2.66	2.65	
120°F (48.9°C)	Total Cap. (MBH)	25.4	25.2	25.0	23.6	23.4	23.2	22.2	22.0	21.8	
	Sensible Cap. (MBH)	15.9	15.7	15.4	19.8	19.3	18.8	22.2	21.8	21.3	
	Power (KW)	2.87	2.85	2.84	2.83	2.82	2.81	2.81	2.80	2.79	
125°F (51.7°C)	Total Cap. (MBH)	24.6	24.4	24.3	22.8	22.7	22.5	21.7	21.4	21.2	
	Sensible Cap. (MBH)	15.6	15.3	15.0	19.5	19.0	18.5	21.7	21.4	20.9	
	Power (KW)	3.04	3.03	3.01	3.00	2.99	2.98	2.98	2.97	2.95	

Power: Total Unit Input Power (KW)
 DR: Depression Ratio
 dbE: Entering Air Temperature in °F

When the entering air dry bulb temperature is other than 80.6°F,
 adjust the sensible capacity from the table by adding 1.1 x CFM X (1-DR) X (dbE-80.6)



GROSS PERFORMANCE DATA

MODEL		RSIN-029T/RSON-030TS									
INDOOR TEMP		80.6 °F (27.0°C) DB / 71.0 °F (21.7°C) WB			80.6 °F (27.0°C) DB / 66.2°F (19.0°C) WB			80.6 °F (27°C) DB / 63.0 °F (17.2°C) WB			
		High	Med	Low	High	Med	Low	High	Med	Low	
DEPRESSION RATIO		0.25	0.27	0.29	0.25	0.27	0.29	0.25	0.27	0.29	
AIR VOL. (CFM)		1275	1225	1170	1275	1225	1170	1275	1225	1170	
O U T D O O R T E M P E R A T U R E	75°F (23.9°C)	Total Cap. (MBH)	34.7	34.5	34.4	32.7	32.5	32.4	31.2	31.0	30.9
		Sensible Cap. (MBH)	21.1	20.8	20.6	26.3	25.9	25.4	30.0	29.4	28.7
		Power (KW)	2.02	2.01	2.00	2.00	1.99	1.98	1.99	1.98	1.97
	80°F (26.7°C)	Total Cap. (MBH)	33.8	33.7	33.6	32.0	31.8	31.7	30.4	30.3	30.2
		Sensible Cap. (MBH)	20.7	20.5	20.2	25.9	25.5	25.1	29.6	29.0	28.4
		Power (KW)	2.12	2.11	2.10	2.11	2.10	2.09	2.10	2.09	2.08
	85°F (29.4°C)	Total Cap. (MBH)	33.0	32.9	32.8	31.3	31.1	30.9	29.8	29.7	29.5
		Sensible Cap. (MBH)	20.3	20.1	19.8	25.6	25.2	24.7	29.3	28.7	28.1
		Power (KW)	2.23	2.22	2.21	2.22	2.21	2.20	2.21	2.20	2.18
	90°F (32.3°C)	Total Cap. (MBH)	32.1	32.0	31.9	30.5	30.4	30.2	29.1	28.9	28.8
		Sensible Cap. (MBH)	19.9	19.7	19.5	25.2	24.8	24.3	28.8	28.4	27.7
		Power (KW)	2.35	2.34	2.33	2.33	2.32	2.31	2.32	2.31	2.30
	95°F (35.0°C)	Total Cap. (MBH)	31.2	31.1	31.1	29.7	29.6	29.5	28.4	28.3	28.1
		Sensible Cap. (MBH)	19.5	19.3	19.1	24.7	24.4	24.0	28.4	28.0	27.4
		Power (KW)	2.47	2.46	2.45	2.45	2.44	2.43	2.44	2.43	2.42
	100°F (37.8°C)	Total Cap. (MBH)	30.3	30.2	30.1	28.9	28.8	28.6	27.8	27.5	27.4
		Sensible Cap. (MBH)	19.0	18.9	18.6	24.4	24.0	23.5	27.8	27.5	27.1
		Power (KW)	2.60	2.59	2.58	2.59	2.57	2.56	2.58	2.56	2.55
	105°F (40.6°C)	Total Cap. (MBH)	29.3	29.2	29.2	28.1	27.9	27.8	27.0	26.8	26.5
		Sensible Cap. (MBH)	18.6	18.4	18.2	23.9	23.5	23.1	27.0	26.8	26.5
		Power (KW)	2.74	2.73	2.72	2.73	2.72	2.70	2.72	2.71	2.69
	110°F (43.3°C)	Total Cap. (MBH)	28.3	28.3	28.2	27.2	27.1	26.9	26.2	26.1	25.8
		Sensible Cap. (MBH)	18.1	17.9	17.7	23.4	23.1	22.7	26.2	26.1	25.8
		Power (KW)	2.89	2.88	2.87	2.88	2.87	2.85	2.87	2.86	2.85
115°F (46.1°C)	Total Cap. (MBH)	27.3	27.2	27.1	26.2	26.1	26.0	25.4	25.3	25.0	
	Sensible Cap. (MBH)	17.5	17.4	17.2	22.9	22.6	22.2	25.4	25.3	25.0	
	Power (KW)	3.05	3.04	3.03	3.04	3.03	3.02	3.03	3.02	3.01	
120°F (48.9°C)	Total Cap. (MBH)	26.3	26.2	26.1	25.2	25.1	25.0	24.6	24.4	24.3	
	Sensible Cap. (MBH)	17.0	16.9	16.6	22.4	22.0	21.6	24.6	24.4	24.3	
	Power (KW)	3.22	3.21	3.20	3.21	3.20	3.19	3.21	3.20	3.19	
125°F (51.7°C)	Total Cap. (MBH)	25.0	25.0	24.9	24.2	24.1	24.0	23.7	23.5	23.3	
	Sensible Cap. (MBH)	16.4	16.2	16.1	21.8	21.5	21.1	23.7	23.5	23.3	
	Power (KW)	3.41	3.40	3.39	3.40	3.39	3.38	3.40	3.39	3.38	

Power: Total Unit Input Power (KW)
 DR: Depression Ratio
 dbE: Entering Air Temperature in °F

When the entering air dry bulb temperature is other than 80.6°F,
 adjust the sensible capacity from the table by adding $1.1 \times \text{CFM} \times (1-\text{DR}) \times (\text{dbE}-80.6)$



GROSS PERFORMANCE DATA

MODEL			RSIN-036T/RSON-036TS								
INDOOR TEMP			80.6 °F (27.0°C) DB / 71.0 °F (21.7°C) WB			80.6 °F (27.0°C) DB / 66.2°F (19.0°C) WB			80.6 °F (27°C) DB / 63.0 °F (17.2°C) WB		
			High	Med	Low	High	Med	Low	High	Med	Low
DEPRESSION RATIO			0.20	0.22	0.24	0.20	0.22	0.24	0.20	0.22	0.24
AIR VOL. (CFM)			1290	1250	1200	1290	1250	1200	1290	1250	1200
O U T D O O R T E M P E R A T U R E	75°F (23.9°C)	Total Cap. (MBH)	44.1	43.9	43.7	41.4	41.2	41.0	39.4	39.3	39.1
		Sensible Cap. (MBH)	26.3	26.0	25.6	32.3	31.8	31.3	36.6	35.9	35.2
		Power (KW)	2.62	2.61	2.61	2.61	2.60	2.60	2.61	2.59	2.59
	80°F (26.7°C)	Total Cap. (MBH)	43.1	42.9	42.7	40.5	40.2	40.0	38.4	38.3	38.1
		Sensible Cap. (MBH)	25.9	25.5	25.2	31.9	31.4	30.8	36.1	35.5	34.8
		Power (KW)	2.75	2.74	2.74	2.74	2.73	2.72	2.73	2.72	2.72
	85°F (29.4°C)	Total Cap. (MBH)	42.1	41.9	41.7	39.5	39.3	39.1	37.4	37.3	37.2
		Sensible Cap. (MBH)	25.4	25.1	24.8	31.4	30.9	30.4	35.7	35.0	34.3
		Power (KW)	2.89	2.88	2.87	2.88	2.86	2.86	2.87	2.85	2.85
	90°F (32.3°C)	Total Cap. (MBH)	41.1	40.9	40.7	38.5	38.4	38.2	36.5	36.3	36.2
		Sensible Cap. (MBH)	25.0	24.7	24.4	31.0	30.5	30.0	35.3	34.7	33.9
		Power (KW)	3.03	3.02	3.01	3.02	3.01	3.00	3.01	3.00	2.99
	95°F (35.0°C)	Total Cap. (MBH)	39.9	39.8	39.6	37.6	37.4	37.2	35.5	35.4	35.2
		Sensible Cap. (MBH)	24.4	24.2	23.9	30.6	30.1	29.5	34.8	34.2	33.6
		Power (KW)	3.18	3.17	3.17	3.17	3.16	3.16	3.16	3.15	3.14
	100°F (37.8°C)	Total Cap. (MBH)	38.9	38.7	38.5	36.6	36.4	36.2	34.6	34.4	34.2
		Sensible Cap. (MBH)	24.0	23.7	23.4	30.1	29.6	29.1	34.4	33.8	33.1
		Power (KW)	3.35	3.34	3.33	3.34	3.32	3.32	3.32	3.31	3.31
	105°F (40.6°C)	Total Cap. (MBH)	37.6	37.5	37.4	35.5	35.4	35.2	33.7	33.4	33.3
		Sensible Cap. (MBH)	23.4	23.2	22.9	29.6	29.1	28.6	33.7	33.3	32.7
		Power (KW)	3.52	3.51	3.50	3.51	3.50	3.49	3.50	3.49	3.48
	110°F (43.3°C)	Total Cap. (MBH)	36.4	36.3	36.2	34.5	34.3	34.1	32.8	32.5	32.3
		Sensible Cap. (MBH)	22.9	22.6	22.4	29.1	28.6	28.1	32.8	32.5	32.2
		Power (KW)	3.70	3.69	3.69	3.70	3.69	3.68	3.69	3.68	3.67
	115°F (46.1°C)	Total Cap. (MBH)	35.2	35.1	35.0	33.4	33.3	33.1	32.0	31.7	31.4
		Sensible Cap. (MBH)	22.3	22.1	21.8	28.6	28.1	27.7	32.0	31.7	31.4
		Power (KW)	3.90	3.89	3.88	3.90	3.89	3.88	3.89	3.88	3.87
120°F (48.9°C)	Total Cap. (MBH)	33.8	33.7	33.6	32.2	32.1	32.0	31.0	30.8	30.5	
	Sensible Cap. (MBH)	21.6	21.4	21.2	28.1	27.6	27.1	31.0	30.8	30.5	
	Power (KW)	4.11	4.10	4.09	4.11	4.10	4.09	4.10	4.09	4.09	
125°F (51.7°C)	Total Cap. (MBH)	32.5	32.4	32.3	30.9	30.9	30.8	30.0	29.8	29.6	
	Sensible Cap. (MBH)	21.0	20.7	20.5	27.5	27.1	26.5	30.0	29.8	29.6	
	Power (KW)	4.33	4.32	4.31	4.33	4.32	4.31	4.33	4.32	4.31	

Power: Total Unit Input Power (KW)
 DR: Depression Ratio
 dbE: Entering Air Temperature in °F

When the entering air dry bulb temperature is other than 80.6°F,
 adjust the sensible capacity from the table by adding 1.1 x CFM X (1-DR) X (dbE-80.6)



GROSS PERFORMANCE DATA

MODEL		RSIN-036T/RSON-036NS									
		80.6 °F (27.0°C) DB / 71.0 °F (21.7°C) WB			80.6 °F (27.0°C) DB / 66.2°F (19.0°C) WB			80.6 °F (27°C) DB / 63.0 °F (17.2°C) WB			
INDOOR TEMP		High	Med	Low	High	Med	Low	High	Med	Low	
DEPRESSION RATIO		0.20	0.22	0.24	0.20	0.22	0.24	0.20	0.22	0.24	
AIR VOL. (CFM)		1290	1250	1200	1290	1250	1200	1290	1250	1200	
O U T D O O R T E M P E R A T U R E	75°F (23.9°C)	Total Cap. (MBH)	43.4	43.2	43.0	41.1	40.9	40.7	39.2	39.0	38.8
		Sensible Cap. (MBH)	25.5	25.3	25.0	31.8	31.3	30.8	36.0	35.2	34.6
		Power (KW)	2.59	2.58	2.57	2.58	2.57	2.56	2.57	2.56	2.55
	80°F (26.7°C)	Total Cap. (MBH)	42.3	42.2	42.1	40.3	40.1	39.9	38.4	38.2	38.0
		Sensible Cap. (MBH)	25.0	24.8	24.5	31.3	30.9	30.4	35.5	34.9	34.2
		Power (KW)	2.72	2.71	2.71	2.71	2.70	2.69	2.70	2.69	2.68
	85°F (29.4°C)	Total Cap. (MBH)	41.2	41.1	41.0	39.4	39.2	39.0	37.5	37.4	37.2
		Sensible Cap. (MBH)	24.5	24.3	24.0	30.9	30.4	30.0	35.2	34.5	33.8
		Power (KW)	2.86	2.85	2.84	2.85	2.84	2.83	2.84	2.83	2.82
	90°F (32.3°C)	Total Cap. (MBH)	40.1	40.0	39.9	38.4	38.2	38.0	36.6	36.4	36.3
		Sensible Cap. (MBH)	23.9	23.7	23.5	30.4	29.9	29.5	34.7	34.0	33.4
		Power (KW)	3.01	3.00	2.99	3.00	2.99	2.98	2.99	2.98	2.97
	95°F (35.0°C)	Total Cap. (MBH)	38.9	38.8	38.7	37.3	37.2	37.0	35.6	35.5	35.3
		Sensible Cap. (MBH)	23.3	23.1	22.9	29.8	29.4	28.9	34.3	33.7	33.0
		Power (KW)	3.16	3.15	3.15	3.15	3.14	3.14	3.14	3.13	3.13
	100°F (37.8°C)	Total Cap. (MBH)	37.6	37.5	37.4	36.2	36.1	35.9	34.6	34.5	34.3
		Sensible Cap. (MBH)	22.7	22.5	22.3	29.1	28.8	28.3	33.8	33.2	32.5
		Power (KW)	3.33	3.32	3.32	3.33	3.32	3.31	3.31	3.30	3.30
	105°F (40.6°C)	Total Cap. (MBH)	36.3	36.3	36.2	35.1	35.0	34.9	33.5	33.4	33.3
		Sensible Cap. (MBH)	22.0	21.8	21.7	28.5	28.1	27.8	33.3	32.6	32.0
		Power (KW)	3.51	3.50	3.50	3.51	3.49	3.49	3.50	3.49	3.48
	110°F (43.3°C)	Total Cap. (MBH)	35.0	34.9	34.8	34.0	33.8	33.7	32.5	32.3	32.2
		Sensible Cap. (MBH)	21.4	21.2	21.1	27.8	27.5	27.1	32.5	32.1	31.6
		Power (KW)	3.71	3.69	3.69	3.70	3.69	3.68	3.69	3.68	3.68
115°F (46.1°C)	Total Cap. (MBH)	33.6	33.6	33.5	32.8	32.7	32.6	31.6	31.3	31.1	
	Sensible Cap. (MBH)	20.7	20.6	20.5	27.1	26.8	26.5	31.6	31.3	31.1	
	Power (KW)	3.91	3.90	3.89	3.91	3.90	3.89	3.90	3.89	3.88	
120°F (48.9°C)	Total Cap. (MBH)	32.3	32.2	32.1	31.6	31.5	31.4	30.5	30.3	30.1	
	Sensible Cap. (MBH)	20.0	19.8	19.8	26.4	26.1	25.7	30.5	30.3	30.1	
	Power (KW)	4.13	4.12	4.11	4.13	4.12	4.11	4.12	4.11	4.10	
125°F (51.7°C)	Total Cap. (MBH)	30.9	30.9	30.8	30.4	30.3	30.2	29.5	29.3	29.1	
	Sensible Cap. (MBH)	19.3	19.2	19.1	25.7	25.4	25.0	29.5	29.3	29.1	
	Power (KW)	4.36	4.35	4.35	4.36	4.35	4.34	4.35	4.34	4.34	

Power: Total Unit Input Power (KW)
 DR: Depression Ratio
 dbE: Entering Air Temperature in °F

When the entering air dry bulb temperature is other than 80.6°F,
 adjust the sensible capacity from the table by adding $1.1 \times \text{CFM} \times (1-\text{DR}) \times (\text{dbE}-80.6)$



GROSS PERFORMANCE DATA

MODEL			RSIN-042T/RSON-042NS								
INDOOR TEMP			80.6 °F (27.0°C) DB / 71.0 °F (21.7°C) WB			80.6 °F (27.0°C) DB / 66.2°F (19.0°C) WB			80.6 °F (27°C) DB / 63.0 °F (17.2°C) WB		
			High	Med	Low	High	Med	Low	High	Med	Low
DEPRESSION RATIO			0.20	0.22	0.24	0.20	0.22	0.24	0.20	0.22	0.24
AIR VOL. (CFM)			1560	1390	1260	1560	1390	1260	1560	1390	1260
O U T D O O R T E M P E R A T U R E	75°F (23.9°C)	Total Cap. (MBH)	47.2	46.7	46.1	44.5	43.7	43.1	42.0	41.4	41.0
		Sensible Cap. (MBH)	28.7	27.8	27.0	35.7	34.1	32.8	40.7	38.6	36.8
		Power (KW)	2.74	2.72	2.70	2.73	2.70	2.69	2.72	2.70	2.68
	80°F (26.7°C)	Total Cap. (MBH)	46.3	45.8	45.3	43.8	43.1	42.5	41.4	40.8	40.4
		Sensible Cap. (MBH)	28.3	27.4	26.6	35.4	33.8	32.5	40.5	38.4	36.5
		Power (KW)	2.88	2.86	2.85	2.87	2.84	2.83	2.86	2.84	2.82
	85°F (29.4°C)	Total Cap. (MBH)	45.3	44.9	44.4	42.9	42.3	41.7	40.6	40.1	39.7
		Sensible Cap. (MBH)	27.8	26.9	26.2	35.0	33.4	32.1	40.2	38.0	36.2
		Power (KW)	3.03	3.00	2.99	3.01	2.99	2.98	3.01	2.98	2.97
	90°F (32.3°C)	Total Cap. (MBH)	44.1	43.7	43.3	42.0	41.4	40.9	39.7	39.2	38.8
		Sensible Cap. (MBH)	27.2	26.4	25.7	34.5	33.0	31.7	39.7	37.5	35.8
		Power (KW)	3.18	3.16	3.15	3.17	3.15	3.13	3.16	3.14	3.12
	95°F (35.0°C)	Total Cap. (MBH)	42.9	42.5	42.2	41.0	40.4	39.9	38.9	38.3	37.8
		Sensible Cap. (MBH)	26.6	25.8	25.2	34.0	32.5	31.3	38.9	37.1	35.4
		Power (KW)	3.34	3.32	3.31	3.33	3.31	3.30	3.32	3.30	3.29
	100°F (37.8°C)	Total Cap. (MBH)	41.6	41.3	41.0	39.8	39.3	38.8	38.0	37.2	36.8
		Sensible Cap. (MBH)	25.9	25.2	24.6	33.4	32.0	30.6	38.0	36.7	35.0
		Power (KW)	3.52	3.49	3.48	3.51	3.48	3.47	3.50	3.48	3.46
	105°F (40.6°C)	Total Cap. (MBH)	40.2	39.9	39.4	38.6	38.1	37.7	37.0	36.1	35.8
		Sensible Cap. (MBH)	25.2	24.6	23.7	32.8	31.4	30.2	37.0	36.1	34.4
		Power (KW)	3.70	3.68	3.66	3.69	3.67	3.66	3.69	3.66	3.65
	110°F (43.3°C)	Total Cap. (MBH)	38.8	38.6	38.3	37.3	37.0	36.6	36.0	35.2	34.6
		Sensible Cap. (MBH)	24.5	23.9	23.4	32.2	30.8	29.7	36.0	35.2	34.0
		Power (KW)	3.90	3.88	3.87	3.89	3.87	3.86	3.89	3.86	3.85
	115°F (46.1°C)	Total Cap. (MBH)	37.4	37.2	37.0	36.0	35.7	35.4	35.0	34.2	33.5
		Sensible Cap. (MBH)	23.7	23.2	22.7	31.6	30.1	29.1	35.0	34.2	33.4
		Power (KW)	4.11	4.09	4.08	4.11	4.09	4.07	4.10	4.08	4.07
120°F (48.9°C)	Total Cap. (MBH)	35.9	35.8	35.6	34.8	34.4	34.2	33.9	33.2	32.5	
	Sensible Cap. (MBH)	23.0	22.4	22.0	31.0	29.2	28.4	33.9	33.2	32.5	
	Power (KW)	4.34	4.32	4.31	4.34	4.31	4.30	4.33	4.31	4.30	
125°F (51.7°C)	Total Cap. (MBH)	34.5	34.3	34.2	33.5	33.2	33.0	32.8	32.2	31.6	
	Sensible Cap. (MBH)	22.2	21.8	21.4	30.3	28.9	27.8	32.8	32.2	31.6	
	Power (KW)	4.58	4.56	4.55	4.58	4.56	4.55	4.58	4.56	4.54	

Power: Total Unit Input Power (KW)
 DR: Depression Ratio
 dbE: Entering Air Temperature in °F

When the entering air dry bulb temperature is other than 80.6°F,
 adjust the sensible capacity from the table by adding $1.1 \times \text{CFM} \times (1-\text{DR}) \times (\text{dbE}-80.6)$



GROSS PERFORMANCE DATA

MODEL		RSIN-048T/RSON-048NS									
INDOOR TEMP		80.6 °F (27.0°C) DB / 71.0 °F (21.7°C) WB			80.6 °F (27.0°C) DB / 66.2°F (19.0°C) WB			80.6 °F (27°C) DB / 63.0 °F (17.2°C) WB			
		High	Med	Low	High	Med	Low	High	Med	Low	
DEPRESSION RATIO		0.21	0.23	0.25	0.21	0.23	0.25	0.21	0.23	0.25	
AIR VOL. (CFM)		1560	1400	1250	1560	1400	1250	1560	1400	1250	
O U T D O O R T E M P E R A T U R E	75°F (23.9°C)	Total Cap. (MBH)	54.2	53.7	53.0	51.4	50.7	49.8	49.0	48.3	47.4
		Sensible Cap. (MBH)	31.8	30.9	30.0	39.2	37.7	36.1	44.2	42.1	40.1
		Power (KW)	3.25	3.18	3.15	3.23	3.16	3.12	3.21	3.14	3.10
	80°F (26.7°C)	Total Cap. (MBH)	53.0	52.4	51.7	50.4	49.6	48.8	48.0	47.3	46.5
		Sensible Cap. (MBH)	31.2	30.4	29.5	38.7	37.2	35.6	43.8	41.6	39.6
		Power (KW)	3.41	3.34	3.31	3.39	3.32	3.28	3.37	3.30	3.26
	85°F (29.4°C)	Total Cap. (MBH)	51.6	51.2	50.6	49.2	48.5	47.5	46.9	46.3	45.5
		Sensible Cap. (MBH)	30.5	29.8	28.9	38.1	36.6	34.7	43.3	41.2	39.1
		Power (KW)	3.58	3.51	3.48	3.56	3.49	3.45	3.54	3.47	3.43
	90°F (32.3°C)	Total Cap. (MBH)	50.2	49.8	49.3	48.1	47.5	46.7	45.8	45.3	44.5
		Sensible Cap. (MBH)	29.9	29.2	28.4	37.5	36.1	34.6	42.7	40.7	38.7
		Power (KW)	3.76	3.69	3.66	3.74	3.67	3.63	3.71	3.65	3.61
	95°F (35.0°C)	Total Cap. (MBH)	48.8	48.5	48.0	46.9	46.3	45.6	44.7	44.1	43.5
		Sensible Cap. (MBH)	29.2	28.5	27.8	36.9	35.5	34.1	42.3	40.2	38.1
		Power (KW)	3.95	3.88	3.85	3.92	3.86	3.82	3.90	3.84	3.80
	100°F (37.8°C)	Total Cap. (MBH)	47.4	47.1	46.7	45.6	45.1	44.5	43.5	43.0	42.4
		Sensible Cap. (MBH)	28.4	27.8	27.1	36.2	34.9	33.5	41.7	39.8	37.7
		Power (KW)	4.14	4.08	4.05	4.12	4.06	4.02	4.10	4.03	4.00
	105°F (40.6°C)	Total Cap. (MBH)	45.9	45.6	45.3	44.3	43.8	43.3	42.3	41.9	41.3
		Sensible Cap. (MBH)	27.7	27.1	26.5	35.5	34.2	32.9	41.2	39.2	37.2
		Power (KW)	4.35	4.29	4.26	4.33	4.27	4.23	4.31	4.24	4.21
	110°F (43.3°C)	Total Cap. (MBH)	44.4	44.2	43.9	43.0	42.5	42.0	41.1	40.7	40.1
		Sensible Cap. (MBH)	27.0	26.4	25.8	34.7	33.5	32.2	40.6	38.7	36.7
		Power (KW)	4.57	4.51	4.47	4.55	4.49	4.45	4.53	4.47	4.43
	115°F (46.1°C)	Total Cap. (MBH)	42.8	42.7	42.4	41.6	41.2	40.8	39.9	39.5	39.0
		Sensible Cap. (MBH)	26.2	25.7	25.1	34.0	32.8	31.6	39.9	38.1	36.3
		Power (KW)	4.80	4.74	4.70	4.78	4.72	4.68	4.76	4.70	4.66
120°F (48.9°C)	Total Cap. (MBH)	41.2	41.1	40.9	40.2	39.9	39.4	38.7	38.2	37.7	
	Sensible Cap. (MBH)	25.4	24.9	24.4	33.1	32.1	30.9	38.7	37.5	35.6	
	Power (KW)	5.04	4.97	4.94	5.02	4.96	4.92	5.00	4.94	4.90	
125°F (51.7°C)	Total Cap. (MBH)	39.6	39.5	39.3	38.8	38.5	38.1	37.5	36.9	36.5	
	Sensible Cap. (MBH)	24.5	24.2	23.7	32.2	31.2	30.2	37.5	36.8	35.0	
	Power (KW)	5.28	5.22	5.19	5.27	5.21	5.17	5.26	5.19	5.15	

Power: Total Unit Input Power (KW)
 DR: Depression Ratio
 dbE: Entering Air Temperature in °F

When the entering air dry bulb temperature is other than 80.6°F,
 adjust the sensible capacity from the table by adding $1.1 \times \text{CFM} \times (1-\text{DR}) \times (\text{dbE}-80.6)$



GROSS PERFORMANCE DATA

MODEL		RSIN-054TN/RSON-054NS									
		80.6 °F (27.0°C) DB / 71.0 °F (21.7°C) WB			80.6 °F (27.0°C) DB / 66.2°F (19.0°C) WB			80.6 °F (27°C) DB / 63.0 °F (17.2°C) WB			
INDOOR TEMP		High	Med	Low	High	Med	Low	High	Med	Low	
DEPRESSION RATIO		0.14	0.16	0.18	0.14	0.16	0.18	0.14	0.16	0.18	
AIR VOL. (CFM)		1825	1720	1640	1825	1720	1640	1825	1720	1640	
O U T D O O T M P E R A T U R E	75°F (23.9°C)	Total Cap. (MBH)	71.1	70.4	69.7	65.5	64.8	64.2	61.7	61.2	60.5
		Sensible Cap. (MBH)	40.6	39.9	39.1	49.1	47.8	46.6	54.8	53.5	51.9
		Power (KW)	4.29	4.24	4.22	4.28	4.23	4.21	4.27	4.22	4.20
	80°F (26.7°C)	Total Cap. (MBH)	69.8	69.3	68.5	64.4	63.8	63.2	60.6	60.2	59.6
		Sensible Cap. (MBH)	40.2	39.4	38.6	48.5	47.4	46.2	54.4	53.1	51.5
		Power (KW)	4.48	4.43	4.40	4.46	4.42	4.39	4.45	4.40	4.38
	85°F (29.4°C)	Total Cap. (MBH)	68.5	67.9	67.3	63.3	62.6	62.0	59.5	59.1	58.5
		Sensible Cap. (MBH)	39.7	38.9	38.1	48.0	46.8	45.7	54.0	52.5	51.1
		Power (KW)	4.67	4.63	4.60	4.66	4.61	4.58	4.64	4.59	4.57
	90°F (32.3°C)	Total Cap. (MBH)	67.1	66.5	65.9	61.9	61.4	60.7	58.3	57.8	57.3
		Sensible Cap. (MBH)	39.2	38.3	37.6	47.5	46.3	45.2	53.5	52.0	50.5
		Power (KW)	4.88	4.84	4.81	4.87	4.82	4.79	4.85	4.80	4.77
	95°F (35.0°C)	Total Cap. (MBH)	65.6	65.1	64.4	60.4	60.0	59.5	56.8	56.4	55.9
		Sensible Cap. (MBH)	38.5	37.7	36.9	46.9	45.8	44.6	52.8	51.5	50.0
		Power (KW)	5.10	5.06	5.03	5.08	5.04	5.01	5.06	5.01	4.98
	100°F (37.8°C)	Total Cap. (MBH)	64.0	63.5	62.9	58.9	58.5	57.9	55.4	55.1	54.5
		Sensible Cap. (MBH)	37.9	37.2	36.3	46.4	45.2	44.0	51.6	50.8	49.4
		Power (KW)	5.34	5.29	5.26	5.32	5.27	5.24	5.38	5.24	5.21
	105°F (40.6°C)	Total Cap. (MBH)	62.3	61.8	61.3	57.4	56.9	56.4	53.6	53.5	53.1
		Sensible Cap. (MBH)	37.2	36.4	35.7	45.8	44.6	43.4	50.9	50.1	48.7
		Power (KW)	5.58	5.53	5.51	5.56	5.52	5.49	5.57	5.49	5.46
	110°F (43.3°C)	Total Cap. (MBH)	60.6	60.1	59.6	55.7	55.3	54.7	52.4	52.0	51.5
		Sensible Cap. (MBH)	36.5	35.8	35.1	45.2	44.0	42.7	50.7	49.4	48.0
		Power (KW)	5.84	5.79	5.77	5.82	5.77	5.75	5.80	5.75	5.72
115°F (46.1°C)	Total Cap. (MBH)	58.8	58.3	57.9	54.0	53.6	53.2	50.7	50.3	49.9	
	Sensible Cap. (MBH)	35.9	35.2	34.3	44.4	43.3	42.1	49.9	48.6	47.3	
	Power (KW)	6.11	6.06	6.04	6.10	6.05	6.02	6.07	6.02	5.99	
120°F (48.9°C)	Total Cap. (MBH)	56.9	56.5	56.1	52.2	51.9	51.5	49.2	48.6	46.8	
	Sensible Cap. (MBH)	35.2	34.4	33.7	43.7	42.5	41.4	48.9	47.8	45.9	
	Power (KW)	6.39	6.35	6.32	6.38	6.34	6.31	6.36	6.31	6.25	
125°F (51.7°C)	Total Cap. (MBH)	55.2	54.7	54.2	50.4	50.0	49.7	47.7	47.1	46.5	
	Sensible Cap. (MBH)	34.4	33.7	32.9	42.9	41.9	40.6	47.7	46.8	45.7	
	Power (KW)	6.69	6.65	6.62	6.69	6.64	6.61	6.67	6.62	6.59	

Power: Total Unit Input Power (KW)
 DR: Depression Ratio
 dbE: Entering Air Temperature in °F

When the entering air dry bulb temperature is other than 80.6°F,
 adjust the sensible capacity from the table by adding $1.1 \times \text{CFM} \times (1-\text{DR}) \times (\text{dbE}-80.6)$



SOUND DATA

Noise level testing of RSIN-T Series IDU

Model	Speed	1/1 Octave Sound Pressure (dB, ref 20µPa)								Overall dBA
		63 Hz	125 Hz	250 Hz	500 Hz	1 KHz	2 KHz	4 KHz	8 KHz	
RSIN-021T	High	47.6	49.9	43.0	41.3	34.7	22.9	17.0	14.3	41.7
	Medium	49.7	49.2	42.5	40.8	34.3	24.9	18.7	14.3	41.3
	Low	48.9	49.1	41.6	40.2	33.9	23.9	18.0	14.4	40.8
RSIN-025T	High	50.8	50.8	51.0	47.5	38.9	30.6	23.6	15.9	47.5
	Medium	50.6	50.1	50.0	46.5	37.9	29.2	22.0	15.5	46.5
	Low	50.5	49.7	49.4	45.8	39.3	31.3	24.2	15.8	46.3
RSIN-029T	High	51.2	55.2	49.9	44.5	41.0	33.6	28.7	19.7	47.1
	Medium	50.6	53.5	49.0	43.9	40.5	32.9	27.8	19.1	46.3
	Low	49.4	51.7	47.9	43.2	40.5	33.9	29.2	19.0	45.8
RSIN-036T	High	50.4	53.5	49.2	44.2	41.3	33.7	28.6	19.4	46.7
	Medium	50.9	52.2	47.7	43.0	40.9	34.4	29.8	19.7	45.9
	Low	51.7	51.4	48.1	42.9	40.1	32.3	26.8	18.2	45.4
RSIN-042T	High	53.8	59.1	51.2	49.3	43.5	39.8	36.1	26.0	50.7
	Medium	56.6	57.6	48.7	47.4	42.2	38.9	35.0	24.6	49.1
	Low	52.9	56.3	48.2	46.6	41.2	37.5	33.3	22.6	48.1
RSIN-048T	High	56.4	61.1	52.6	50.8	45.3	41.9	38.6	29.0	52.5
	Medium	53.8	59.1	51.2	49.3	43.5	39.8	36.1	26.0	50.7
	Low	56.6	57.6	48.7	47.4	42.2	38.9	35.0	24.6	49.1
RSIN-054TN	High	53.9	59.5	56.9	51.9	45.6	40.8	36.3	28.8	53.4
	Medium	52.3	58.1	56.0	51.3	44.8	39.8	35.2	27.6	52.6
	Low	53.9	57.4	55.1	50.6	44.1	38.9	33.9	26.3	51.8

Sound Testing Arrangement

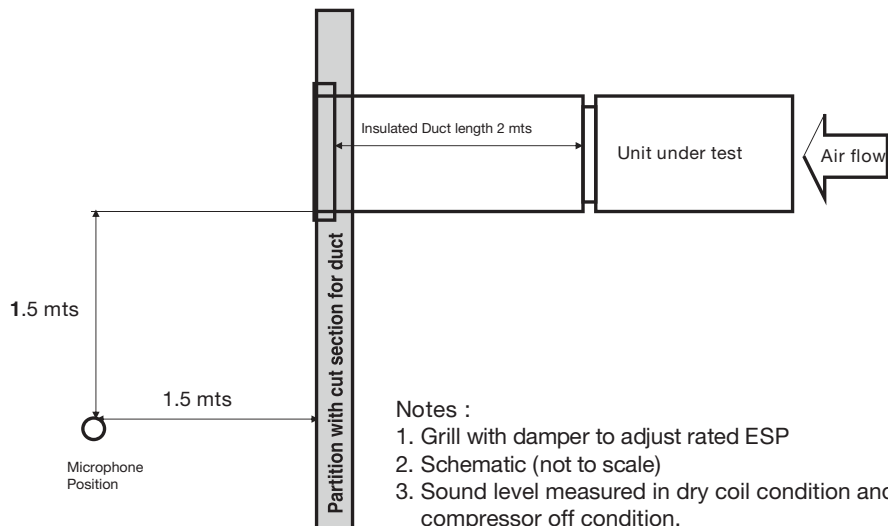

AIR FLOW PERFORMANCE DATA

AIR FLOW PERFORMANCE DATA - RSIN-T 50Hz

MODEL	BLOWER MOTOR SPEED	PERFORMANCE	CFM @ EXTERNAL STATIC PRESSURE (Inches of Water)					
			0	0.1	0.15	0.2	0.3	0.4
RSIN-021T	LOW	CFM	890	745	645	425	-	-
		POWER	90	80	70	60	-	-
	MED	CFM	925	770	665	450	-	-
		POWER	95	85	75	65	-	-
	HIGH	CFM	955	790	685	470	-	-
		POWER	100	90	80	70	-	-
RSIN-025T	LOW	CFM	890	795	745	695	520	-
		POWER	130	125	120	115	110	-
	MED	CFM	930	840	795	740	585	-
		POWER	140	135	130	125	120	-
	HIGH	CFM	980	890	845	790	640	-
		POWER	150	145	140	135	130	-
RSIN-029T	LOW	CFM	1360	1240	1170	1075	655	-
		POWER	200	170	160	140	100	-
	MED	CFM	1440	1300	1225	1125	720	-
		POWER	210	180	170	150	110	-
	HIGH	CFM	1540	1360	1275	1170	750	-
		POWER	220	190	180	160	120	-
RSIN-036T	LOW	CFM	1420	1280	1200	1100	635	-
		POWER	200	180	165	150	100	-
	MED	CFM	1485	1330	1250	1145	705	-
		POWER	210	185	170	160	120	-
	HIGH	CFM	1560	1385	1290	1185	720	-
		POWER	220	190	180	170	130	-
RHLH-042T	LOW	CFM	1310	1290	1260	1180	880	470
		POWER	250	240	230	200	150	120
	MED	CFM	1520	1460	1390	1250	890	480
		POWER	290	250	230	200	150	120
	HIGH	CFM	1810	1660	1560	1400	980	480
		POWER	310	270	250	230	180	140
RSIN-048T	LOW	CFM	1520	1460	1390	1250	890	480
		POWER	290	250	230	200	150	120
	MED	CFM	1810	1660	1560	1400	980	480
		POWER	310	270	250	230	180	140
	HIGH	CFM	2025	1810	1700	1560	1200	540
		POWER	360	330	310	290	260	210
RSIN-054TN	LOW	CFM	1965	1830	1740	1640	1200	475
		POWER	365	325	305	295	245	180
	MED	CFM	2130	1950	1835	1720	1265	490
		POWER	395	355	335	320	275	205
	HIGH	CFM	2285	2065	1935	1825	1370	530
		POWER	435	400	385	365	325	270



GENERAL ARRANGEMENT DRAWING Indoor Units.

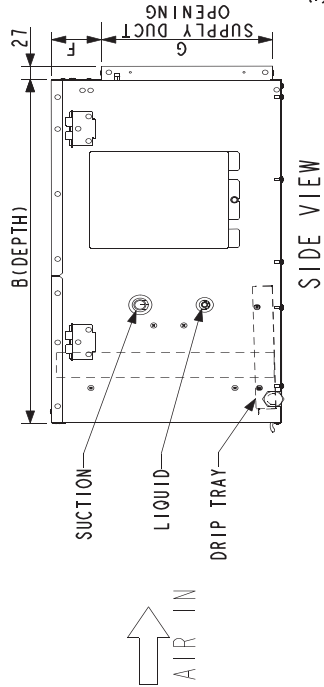
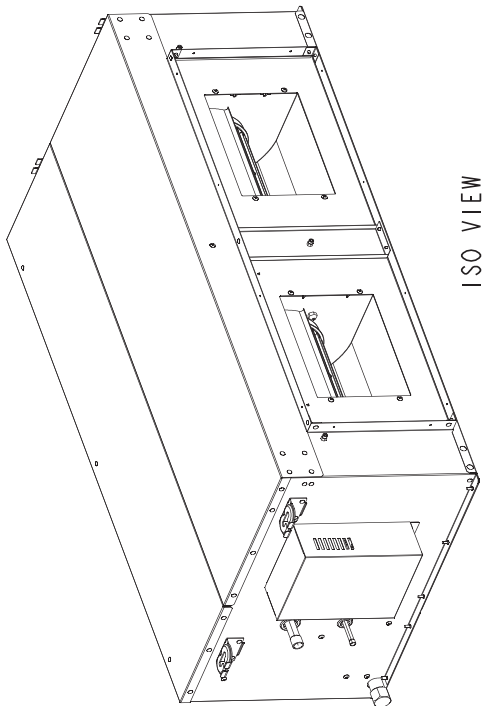
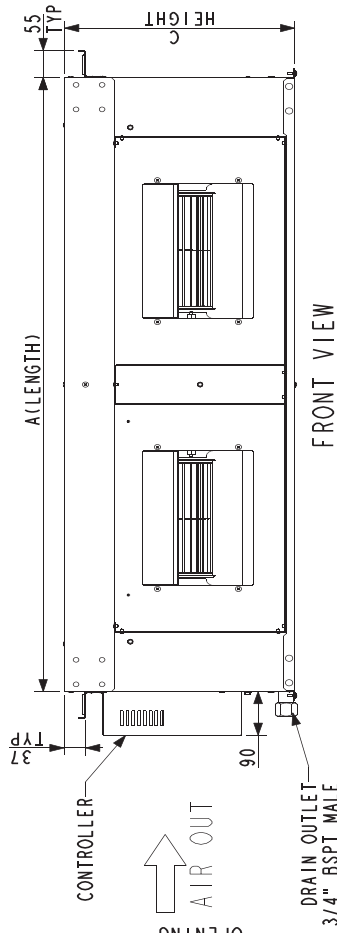
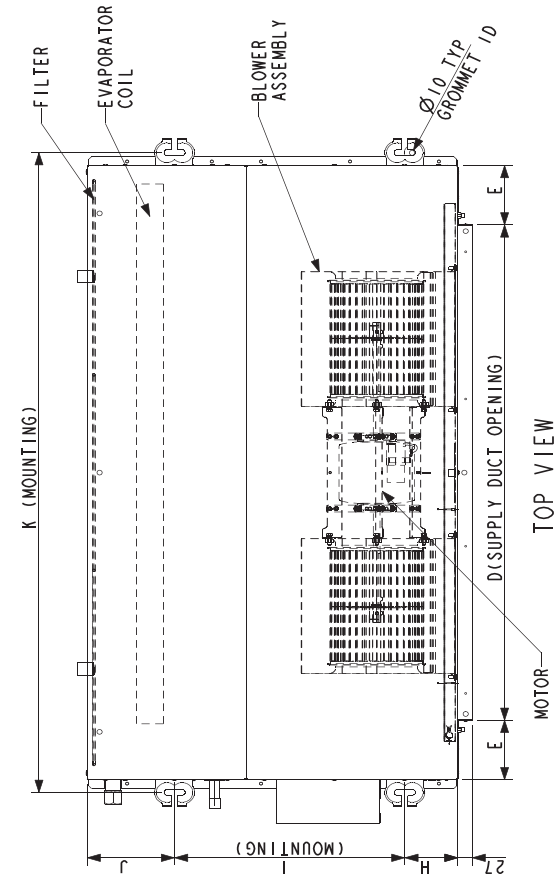

MODEL	A	B	C	D	E	F	G	H	I	J	K	SUC. SIZE	LIQ. SIZE
RSIN-021/25T	1252	600	310	1010	121	52	242	75	390	135	1304	5/8"	3/8"
RSIN-029/36T	1252	700	400	1010	121	87	297	100	435	165	1304	5/8"	3/8"
RSIN-042/48T	1402	700	400	1010	196	87	297	100	435	165	1454	3/4"	3/8"
RSIN-054TN	1402	700	479	1010	196	120	342	100	435	165	1454	3/4"	3/8"



The new degree of comfort.™

GENERAL ARRANGEMENT DRAWING Outdoor Units.

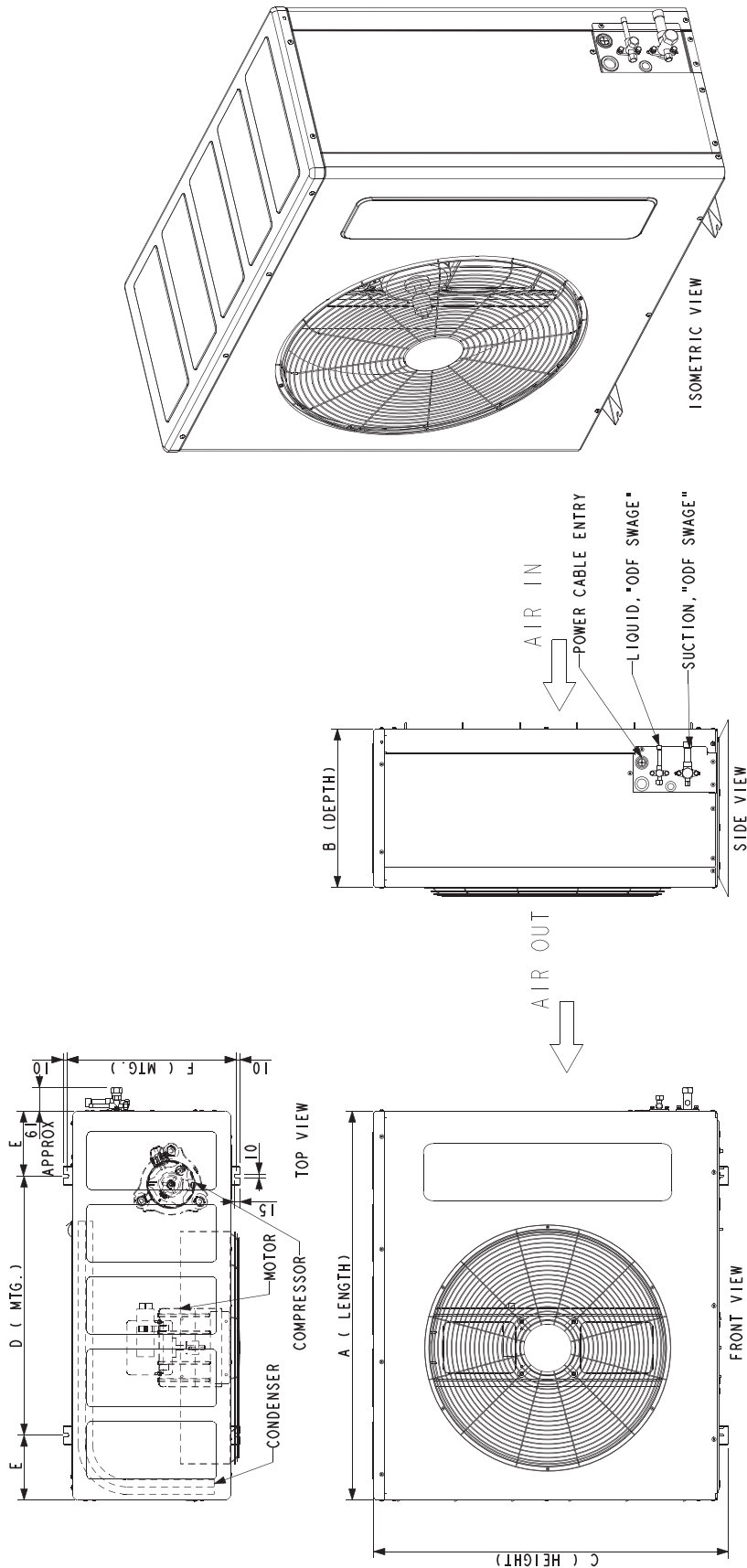

MODEL - 50Hz	A	B	C	D	E	F	SUCTION CONNECTION	LIQUID CONNECTION
RSON-021TS	850	310	690	595	125	350	5/8"	3/8"
RSON-025TS	850	310	800	595	125	350	5/8"	3/8"
RSON-030TS / RSON-036TS / RSON-036NS	1020	416	930	680	170	445	5/8"	3/8"
RSON-042NS / RSON-048NS	1020	416	930	680	170	445	3/4"	3/8"
RSON-054NS	1020	416	1045	680	170	445	3/4"	3/8"

ELECTRICAL WIRING DIAGRAM (Indoor Unit)

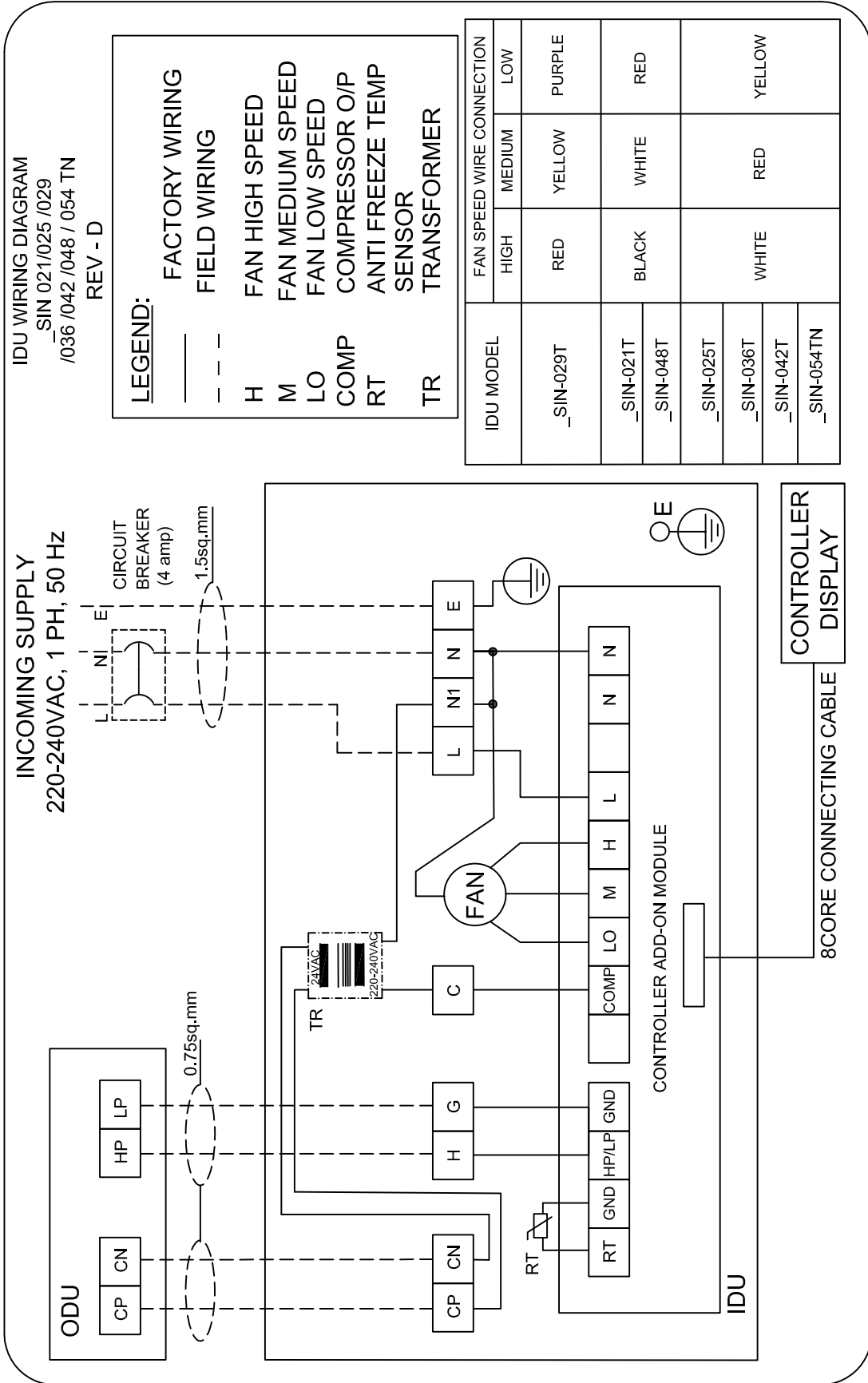

ELECTRICAL WIRING DIAGRAM (Outdoor Unit)

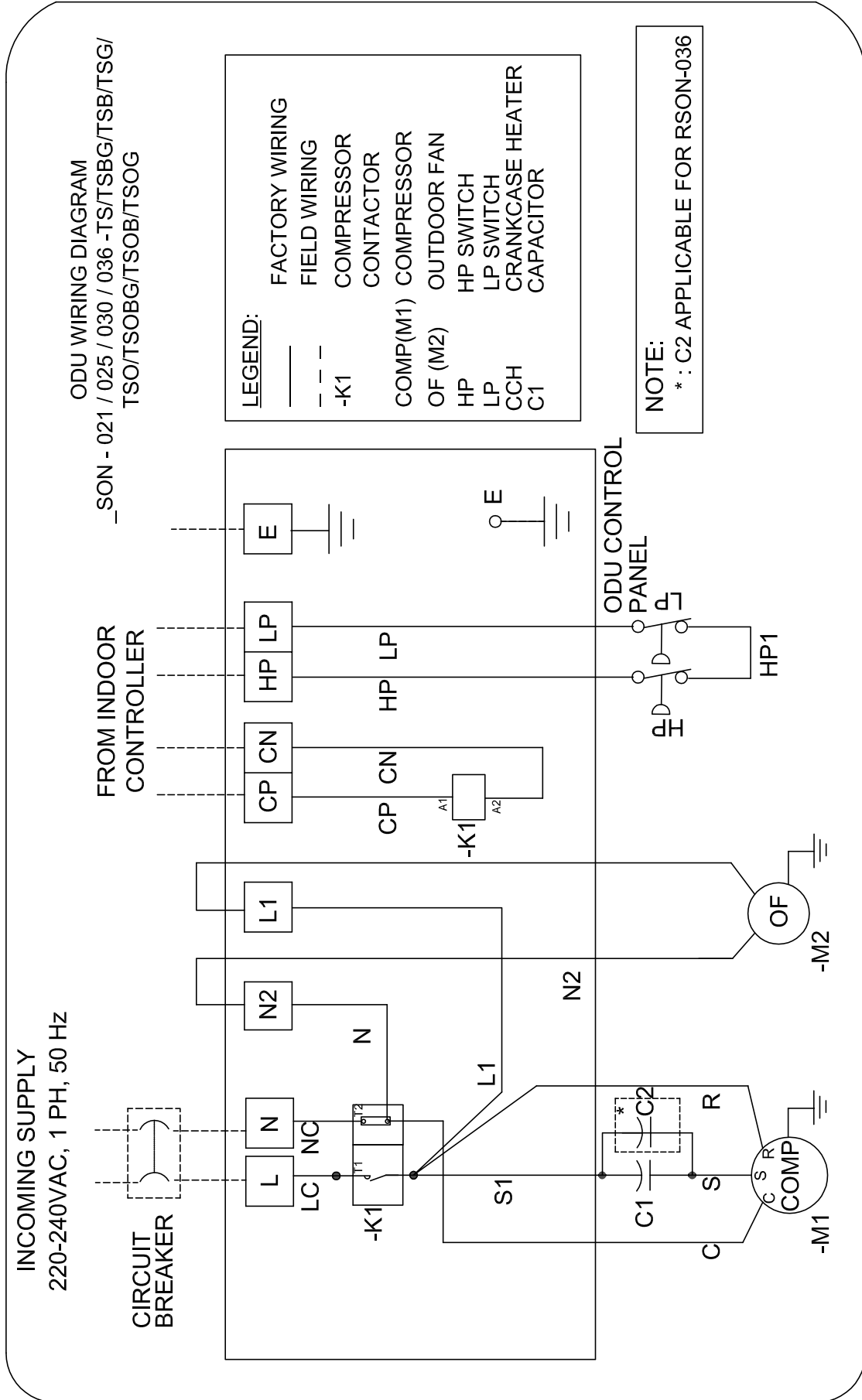

ELECTRICAL WIRING DIAGRAM (Outdoor Unit)

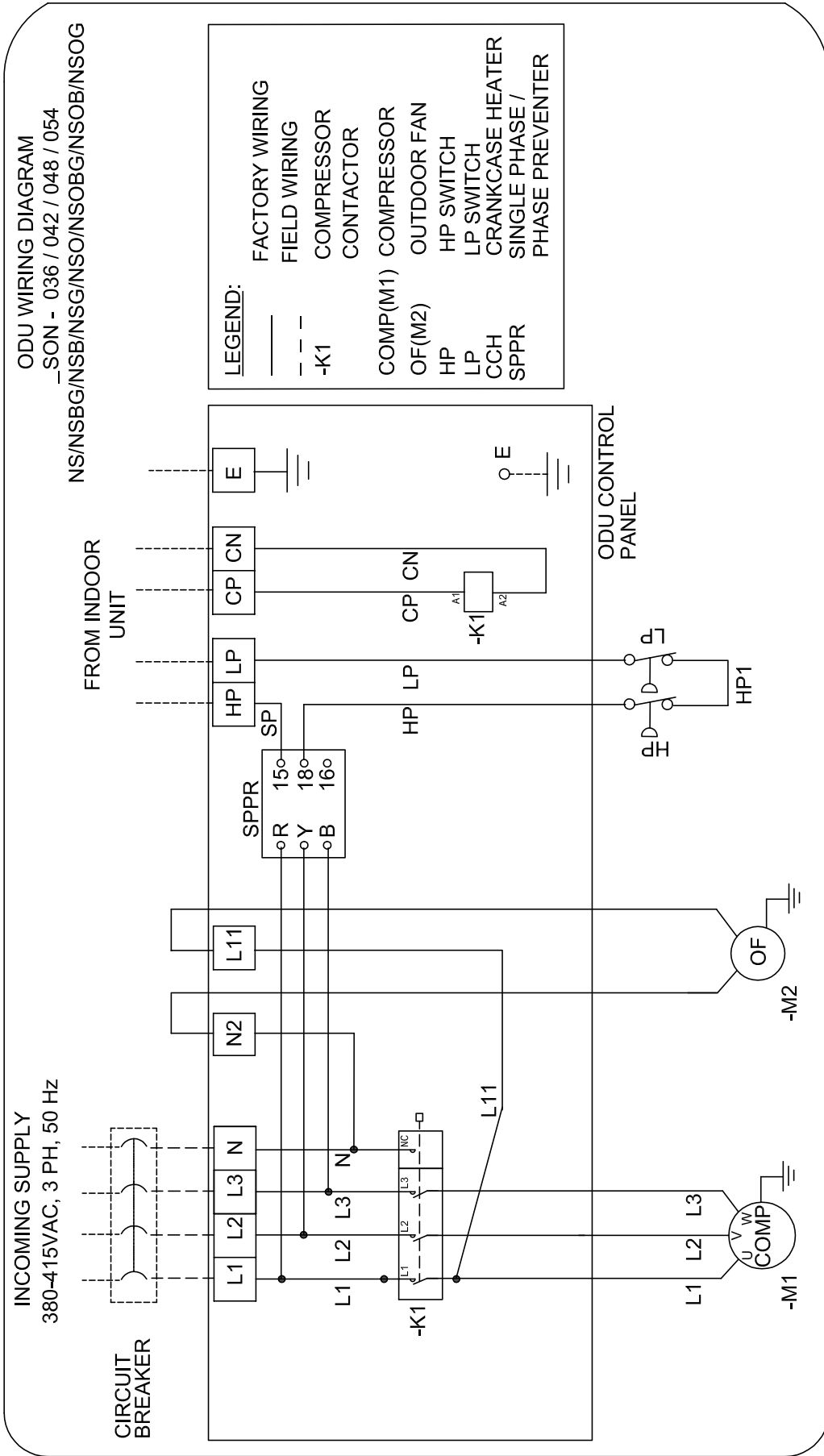

PIPE SIZE CHART

Outdoor Unit ABOVE Indoor Unit																
Single Stage	Liquid Line Size [mm]	Suction Line Size [mm]	Equivalent Length in Meters													
			Condition - A			Condition - B			Condition - C							
			15.5-22.5	23-45	38-45	45-75	75-90	45.5-52.5	53-60	61.5-67.5	68-75	75.5-82.5	83-90			
Maximum Vertical Separation / Capacity Multiplier																
	1/4" [6.35]	5/8" [15.88]	15 / 1.00	22.5 / 0.99	33.5 / 0.99	40 / 0.98	N/A	N/A	N/A	N/A	52.5 / 0.97	N/A	N/A	N/A	N/A	N/A
RSON-021TS	5/16" [7.94]	5/8" [15.88]	15 / 1.00	22.5 / 0.99	33.5 / 0.98	40 / 0.98	45 / 0.96	45 / 0.95	45 / 0.96	58 / 0.97	52.5 / 0.97	56 / 0.96	55 / 0.96	52.5 / 0.96	60 / 0.96	52.5 / 0.95
	3/8" [9.52.5]	5/8" [15.88]	15 / 1.00	22.5 / 0.99	33.5 / 0.98	40 / 0.98	45 / 0.96	45 / 0.95	45 / 0.95	60 / 0.97	52.5 / 0.97	60 / 0.96	60 / 0.96	60 / 0.96	60 / 0.96	60 / 0.95
RSON-025TS	1/4" [6.35]	5/8" [15.88]	15 / 1.00	22.5 / 0.99	33.5 / 0.98	N/A	N/A	N/A	N/A	N/A	N/A	N/A	N/A	N/A	N/A	N/A
	5/16" [7.94]	5/8" [15.88]	15 / 1.00	22.5 / 0.99	33.5 / 0.98	40 / 0.97	45 / 0.95	45 / 0.95	45 / 0.94	55 / 0.96	52 / 0.97	50 / 0.95	47 / 0.95	N/A	N/A	N/A
	3/8" [9.52.5]	5/8" [15.88]	15 / 1.00	22.5 / 0.99	33.5 / 0.98	40 / 0.97	45 / 0.95	45 / 0.95	45 / 0.94	60 / 0.96	52.5 / 0.97	60 / 0.95	60 / 0.95	60 / 0.95	60 / 0.95	60* / 0.94
RSON-030TS	5/16" [7.94]	5/8" [15.88]	15 / 0.98	22.5 / 0.97	33.5 / 0.97	40 / 0.95	N/A	N/A	N/A	N/A	N/A	N/A	N/A	N/A	N/A	N/A
	3/8" [9.52.5]	5/8" [15.88]	15 / 0.98	22.5 / 0.97	33.5 / 0.97	40 / 0.95	45 / 0.92	45 / 0.91	45 / 0.91	60 / 0.93	52.5 / 0.94	60 / 0.93	60 / 0.92	60 / 0.92	60 / 0.92	60* / 0.91
	5/16" [7.94]	3/4" [19.06]	15 / 1.00	22.5 / 0.99	33.5 / 0.99	40 / 0.98	N/A	N/A	N/A	N/A	N/A	N/A	N/A	N/A	N/A	N/A
	3/8" [9.52.5]	3/4" [19.06]	15 / 1.00	22.5 / 0.99	33.5 / 0.99	40 / 0.98	45 / 0.97	45 / 0.96	45 / 0.96	60 / 0.98	52.5 / 0.98	60 / 0.97	60 / 0.97	60 / 0.97	60 / 0.97	60* / 0.96
	5/16" [7.94]	5/8" [15.88]	15 / 0.98	22.5 / 0.97	33.5 / 0.96	40 / 0.93	N/A	N/A	N/A	N/A	N/A	N/A	N/A	N/A	N/A	N/A
	3/8" [9.52.5]	5/8" [15.88]	15 / 0.98	22.5 / 0.97	33.5 / 0.96	40 / 0.93	45 / 0.90	45 / 0.88	45 / 0.88	60 / 0.91	52.5 / 0.93	60 / 0.90	60 / 0.90	60 / 0.90	60 / 0.89	60* / 0.88
RSON-036TS/NS	5/16" [7.94]	3/4" [19.06]	15 / 1.00	22.5 / 0.99	33.5 / 0.99	40 / 0.98	N/A	N/A	N/A	N/A	N/A	N/A	N/A	N/A	N/A	N/A
	3/8" [9.52.5]	3/4" [19.06]	15 / 1.00	22.5 / 1.00	33.5 / 0.99	40 / 0.97	45 / 0.97	45 / 0.96	45 / 0.96	60 / 0.98	52.5 / 0.96	60 / 0.97	60 / 0.97	60 / 0.97	60 / 0.96	60* / 0.96
	5/16" [7.94]	3/4" [19.06]	15 / 1.00	22.5 / 0.99	33.5 / 0.99	N/A	N/A	N/A	N/A	N/A	N/A	N/A	N/A	N/A	N/A	N/A
RSON-042NS	3/8" [9.52.5]	3/4" [19.06]	15 / 1.00	22.5 / 0.99	33.5 / 0.99	40 / 0.98	45 / 0.96	45 / 0.95	45 / 0.95	60 / 0.97	52.5 / 0.98	60 / 0.97	60 / 0.97	60* / 0.96	60* / 0.96	60* / 0.95
	5/16" [7.94]	7/8" [22.22.5]	15 / 1.00	22.5 / 1.00	33.5 / 1.00	N/A	N/A	N/A	N/A	N/A	N/A	N/A	N/A	N/A	N/A	N/A
	3/8" [9.52.5]	7/8" [22.22.5]	15 / 1.00	22.5 / 1.00	33.5 / 1.00	40 / 1.00	45 / 0.96	45 / 0.95	45 / 0.95	60 / 0.99	52.5 / 0.99	60 / 0.99	60 / 0.99	60* / 0.96	60* / 0.96	60* / 0.95
	1/2" [12.71]	3/4" [19.06]	15 / 0.98	22.5 / 0.97	33.5 / 0.96	40 / 0.95	45 / 0.92	45 / 0.91	45 / 0.91	60 / 0.93	52.5 / 0.94	60* / 0.93	60* / 0.92	58* / 0.92	52* / 0.92	47* / 0.91
RSON-048NS	3/8" [9.52.5]	7/8" [22.22.5]	15 / 1.00	22.5 / 0.98	33.5 / 0.98	40 / 0.97	45 / 0.96	45 / 0.95	45 / 0.95	60 / 0.97	52.5 / 0.97	60 / 0.96	60 / 0.96	60 / 0.96	60 / 0.96	60* / 0.91
	1/2" [12.71]	7/8" [22.22.5]	15 / 1.00	22.5 / 0.98	33.5 / 0.98	40 / 0.97	45 / 0.96	45 / 0.96	45 / 0.96	60 / 0.97	52.5 / 0.97	60 / 0.97	60 / 0.96	58* / 0.96	52* / 0.96	47* / 0.96
	3/8" [9.52.5]	3/4" [19.06]	15 / 0.98	22.5 / 0.96	33.5 / 0.95	40 / 0.93	45 / 0.90	N/A	N/A	60* / 0.92	52.5 / 0.92	60* / 0.92	55* / 0.91	49* / 0.90	N/A	N/A
RSON-054NS	1/2" [12.71]	3/4" [19.06]	15 / 0.98	22.5 / 0.96	33.5 / 0.95	40 / 0.93	45 / 0.90	45 / 0.89	45 / 0.89	60 / 0.92	52.5 / 0.92	60 / 0.92	60 / 0.91	60 / 0.90	60* / 0.90	60* / 0.89
	3/8" [9.52.5]	7/8" [22.22.5]	15 / 1.00	22.5 / 0.99	33.5 / 0.98	40 / 0.97	45 / 0.95	N/A	N/A	60* / 0.96	52.5 / 0.97	60* / 0.96	55* / 0.96	49* / 0.95	N/A	N/A
	1/2" [12.71]	7/8" [22.22.5]	15 / 1.00	22.5 / 0.99	33.5 / 0.98	40 / 0.97	45 / 0.95	45 / 0.95	45 / 0.94	60 / 0.96	52.5 / 0.97	60 / 0.96	60 / 0.96	60 / 0.95	60* / 0.95	60* / 0.94

Note: This chart is applicable for ODU with scroll compressor only.

Light Gray - (<45m vertical separation)

Dark Gray

Black

Use Oil Separator and Crank case heater. (Less than 45m vertical separation)

Use Oil Separator, Crank case heater, Hard Start Kit and Non-bleed TXX.

Not Recommended

* Applications with asterisks (*) require a minimum of 1.5m vertical separation.

Condition	Total Equivalent Length	Max. Vertical Separation
A	3 ~ 45	<33.5
B	45 ~ 90	34 ~ 45
C	45 ~ 90	45.1 ~ 60



PIPE SIZE CHART

Single Stage	Liquid Line Size [mm]	Suction Line Size [mm]	Outdoor Unit BELOW Indoor Unit														
			Equivalent Length in Meter														
			<15	15.5-22.5	23-30	30.5-37.5	38 - 45	45.5-52.5	53-60	61.5-67.5	68-75	75.6-82.5	83-90				
RSON-021TS	5/16" [7.94]	5/8" [15.88]	15/0.99	21.0/0.99	18/0.98	13.5/0.98	10.5/0.98	60.97	3/0.97	N/A	N/A	N/A	N/A	N/A	N/A		
	3/8" [9.52.5]	5/8" [15.88]	15/0.99	22.5/0.99	24.5/0.98	24.5/0.98	24.5/0.98	24.5/0.97	24.5/0.97	24.5/0.96	24.5/0.96	24.5/0.96	24.5/0.96	24.5/0.96	18/0.96	15/0.95	
	5/16" [7.94]	3/4" [19.06]	15/1.00	21.0/1.00	18/1.00	13.5/1.00	10.5/0.99	60.99	3/0.99	N/A	N/A	N/A	N/A	N/A	N/A	N/A	
	3/8" [9.52.5]	3/4" [19.06]	15/1.00	22.5/1.00	24.5/1.00	24.5/1.00	24.5/1.00	24.5/0.99	24.5/0.99	24.5/0.99	24.5/0.99	24.5/0.99	24.5/0.99	24.5/0.99	24.5/0.99	18/0.99	15/0.99
	5/16" [7.94]	5/8" [15.88]	15/1.00	13.5/0.99	25/0.98	N/A	N/A	N/A	N/A	N/A	N/A	N/A	N/A	N/A	N/A	N/A	N/A
	3/8" [9.52.5]	5/8" [15.88]	15/1.00	22.5/0.99	24.5/0.98	24.5/0.97	24.5/0.97	24.5/0.97	24.5/0.96	24.5/0.95	24.5/0.94	24.5/0.93	24.5/0.93	24.5/0.93	24.5/0.94	9/0.94	3/0.93
RSON-025TS	5/16" [7.94]	3/4" [19.06]	15/1.00	13.5/1.00	25/1.00	N/A	N/A	N/A	N/A	N/A	N/A	N/A	N/A	N/A	N/A	N/A	
	3/8" [9.52.5]	3/4" [19.06]	15/1.00	22.5/1.00	24.5/1.00	24.5/1.00	24.5/0.99	24.5/0.99	24.5/0.99	24.5/0.99	24.5/0.99	24.5/0.99	24.5/0.99	24.5/0.98	9/0.98	3/0.98	
	5/16" [7.94]	5/8" [15.88]	12/09.8	3/0.97	N/A	N/A	N/A	N/A	N/A	N/A	N/A	N/A	N/A	N/A	N/A	N/A	
	3/8" [9.52.5]	5/8" [15.88]	15/0.98	22.5/0.97	24.5/0.97	24.5/0.96	24.5/0.96	24.5/0.95	24.5/0.94	24.5/0.93	24.5/0.93	24.5/0.93	24.5/0.93	24.5/0.92	15/0.92	N/A	
	5/16" [7.94]	3/4" [19.06]	12/1.00	3/0.99	N/A	N/A	N/A	N/A	N/A	N/A	N/A	N/A	N/A	N/A	N/A	N/A	N/A
	3/8" [9.52.5]	3/4" [19.06]	15/1.00	22.5/0.99	24.5/0.99	24.5/0.99	24.5/0.99	24.5/0.98	24.5/0.98	24.5/0.98	24.5/0.98	24.5/0.98	24.5/0.97	24.5/0.97	15/0.97	N/A	
RSON-030TS	5/16" [7.94]	3/4" [19.06]	10.5/1.00	10/0.99	N/A	N/A	N/A	N/A	N/A	N/A	N/A	N/A	N/A	N/A	N/A	N/A	
	3/8" [9.52.5]	3/4" [19.06]	15/1.00	22.5/0.99	24.5/0.98	24.5/0.98	24.5/0.98	24.5/0.97	24.5/0.97	24.5/0.97	24.5/0.97	24.5/0.97	24.5/0.96	24.5/0.96	10/0.96	N/A	
	1/2" [12.71]	3/4" [19.06]	15/1.00	22.5/0.99	24.5/0.98	24.5/0.98	24.5/0.98	24.5/0.97	24.5/0.97	24.5/0.97	24.5/0.97	24.5/0.97	24.5/0.97	24.5/0.96	24.5/0.96	24.5/09.5	
	3/8" [9.52.5]	7/8" [22.23]	15/1.00	22.5/1.00	24.5/1.00	24.5/1.00	24.5/1.00	24.5/0.99	24.5/0.99	24.5/0.99	24.5/0.99	24.5/0.99	24.5/0.99	24.5/0.98	10/0.98	N/A	
	1/2" [12.71]	7/8" [22.23]	15/1.00	22.5/1.00	24.5/1.00	24.5/1.00	24.5/1.00	24.5/0.99	24.5/0.99	24.5/0.99	24.5/0.99	24.5/0.99	24.5/0.99	24.5/0.98	24.5/0.98	24.5/0.98	
	3/8" [9.52.5]	3/4" [19.06]	15/0.99	22.5/0.99	24.5/0.98	24.5/0.98	24.5/0.97	24.5/0.97	24.5/0.97	24.5/0.96	24.5/0.96	24.5/0.96	24.5/0.96	24.5/0.95	21.0/0.95	N/A	
RSON-042NS	1/2" [12.71]	3/4" [19.06]	15/0.99	22.5/0.99	24.5/0.98	24.5/0.98	24.5/0.97	24.5/0.97	24.5/0.96	24.5/0.96	24.5/0.96	24.5/0.96	24.5/0.95	21.0/0.95	18/0.94	N/A	
	3/8" [9.52.5]	7/8" [22.23]	15/1.00	22.5/1.00	24.5/1.00	24.5/1.00	24.5/1.00	24.5/0.99	24.5/0.99	24.5/0.99	24.5/0.99	24.5/0.99	24.5/0.98	21.0/0.98	N/A	N/A	
	1/2" [12.71]	7/8" [22.23]	15/1.00	22.5/1.00	24.5/1.00	24.5/1.00	24.5/1.00	24.5/0.99	24.5/0.99	24.5/0.99	24.5/0.99	24.5/0.99	24.5/0.98	21.0/0.98	18/0.97	N/A	
	3/8" [9.52.5]	3/4" [19.06]	15/0.99	22.5/0.99	24.5/0.98	24.5/0.98	24.5/0.97	24.5/0.97	24.5/0.96	24.5/0.96	24.5/0.96	24.5/0.96	24.5/0.95	15/0.95	N/A	N/A	
	1/2" [12.71]	3/4" [19.06]	15/0.99	22.5/0.99	24.5/0.98	24.5/0.98	24.5/0.97	24.5/0.97	24.5/0.96	24.5/0.96	24.5/0.96	24.5/0.96	24.5/0.95	18/0.95	12/0.94	N/A	
	3/8" [9.52.5]	7/8" [22.23]	15/1.00	22.5/1.00	24.5/1.00	24.5/1.00	24.5/1.00	24.5/0.99	24.5/0.99	24.5/0.99	24.5/0.99	24.5/0.99	24.5/0.98	21.0/0.98	18/0.98	12/0.97	
RSON-048NS	1/2" [12.71]	7/8" [22.23]	15/1.00	22.5/1.00	24.5/1.00	24.5/1.00	24.5/1.00	24.5/0.99	24.5/0.99	24.5/0.99	24.5/0.99	24.5/0.99	24.5/0.98	21.0/0.98	18/0.98	N/A	
	3/8" [9.52.5]	3/4" [19.06]	15/0.98	22.5/0.98	24.5/0.97	24.5/0.96	24.5/0.96	24.5/0.95	24.5/0.95	24.5/0.95	24.5/0.95	24.5/0.94	6/0.94	N/A	N/A	N/A	
	1/2" [12.71]	3/4" [19.06]	15/0.98	22.5/0.98	24.5/0.97	24.5/0.96	24.5/0.96	24.5/0.95	24.5/0.95	24.5/0.95	24.5/0.94	15/0.94	9/0.93	N/A	N/A	N/A	
	3/8" [9.52.5]	7/8" [22.23]	15/1.00	22.5/0.99	24.5/0.99	24.5/0.98	24.5/0.98	24.5/0.97	24.5/0.97	24.5/0.96	24.5/0.96	24.5/0.96	24.5/0.95	15/0.95	12/0.94	N/A	
	1/2" [12.71]	3/4" [19.06]	15/1.00	22.5/0.99	24.5/0.99	24.5/0.99	24.5/0.99	24.5/0.99	24.5/0.99	24.5/0.99	24.5/0.99	24.5/0.99	24.5/0.98	21.0/0.98	18/0.98	12/0.97	
	3/8" [9.52.5]	7/8" [22.23]	15/1.00	22.5/0.99	24.5/0.99	24.5/0.98	24.5/0.98	24.5/0.97	24.5/0.97	24.5/0.96	24.5/0.96	24.5/0.96	24.5/0.95	15/0.95	12/0.94	N/A	
RSON-054NS	1/2" [12.71]	3/4" [19.06]	15/1.00	22.5/0.99	24.5/0.99	24.5/0.98	24.5/0.98	24.5/0.97	24.5/0.97	24.5/0.96	24.5/0.96	24.5/0.96	24.5/0.95	15/0.95	12/0.94	N/A	
	3/8" [9.52.5]	7/8" [22.23]	15/1.00	22.5/0.99	24.5/0.99	24.5/0.98	24.5/0.98	24.5/0.97	24.5/0.97	24.5/0.96	24.5/0.96	24.5/0.96	24.5/0.95	15/0.95	12/0.94	N/A	
	1/2" [12.71]	7/8" [22.23]	15/1.00	22.5/0.99	24.5/0.99	24.5/0.98	24.5/0.98	24.5/0.97	24.5/0.97	24.5/0.96	24.5/0.96	24.5/0.96	24.5/0.95	15/0.95	12/0.94	N/A	
	3/8" [9.52.5]	3/4" [19.06]	15/1.00	22.5/0.99	24.5/0.99	24.5/0.98	24.5/0.98	24.5/0.97	24.5/0.97	24.5/0.96	24.5/0.96	24.5/0.96	24.5/0.95	15/0.95	12/0.94	N/A	
	1/2" [12.71]	7/8" [22.23]	15/1.00	22.5/0.99	24.5/0.99	24.5/0.98	24.5/0.98	24.5/0.97	24.5/0.97	24.5/0.96	24.5/0.96	24.5/0.96	24.5/0.95	15/0.95	12/0.94	N/A	
	3/8" [9.52.5]	7/8" [22.23]	15/1.00	22.5/0.99	24.5/0.99	24.5/0.98	24.5/0.98	24.5/0.97	24.5/0.97	24.5/0.96	24.5/0.96	24.5/0.96	24.5/0.95	15/0.95	12/0.94	N/A	

Always Use the smallest Liquid Line allowable to keep system charge to a minimum
 Areas in light grey shade requires long line set application (Use Oil Separator, Crank case heater, Hard Start Kit and Non-bleed TXV).
 Do not use line sets in areas shaded in Dark Grey
 Vertical separation cannot Exceed 24.5 meter of length.

Note: This chart is applicable for ODU with scroll compressor only



Notes



The new degree of comfort.™





The new degree of comfort.™

Why Rheem?

American Brand with Global Reach,
Dedicated to Quality & Innovation

Rheem is the only North American manufacturer delivering advanced, energy-efficient air and water solutions to homes and businesses in more than 70 countries worldwide. From its Atlanta Headquarters, three U.S. manufacturing facilities and Advanced Technology Integration (ATI) Lab along with its manufacturing, research and development centers all around the world, Rheem designs, builds and supplies some of the most reliable, environmentally responsible and high-performance products in the industry.

In the Middle East, Rheem has been present and its products are in service for over 30 years. In fact, the company has already installed more than one million ton of air-conditioning products.

Rheem products include (but not limited to):

- Full range of direct expansion Air-conditioning solutions such as Rooftop package units, ducted units, decorative splits.
- Advanced Integrated Air-conditioning, Heating & Water Heating energy saving and comfort systems such as H2AC and HumidiDry.
- Full range of water heating products including electric tank and tankless water heaters (electric and gas), boilers, heat-pump water heaters and solar powered water heating solutions.

For more information about our products and local distributors, please visit us at
www.Rheem-mea.com



For continuous product improvement, Rheem reserves the right to make changes to the product specifications without notice.